

Instruction Manual

18B4B Vapour Booster Pumps





Declaration of Conformity

We, Edwards,
Manor Royal,
Crawley,
West Sussex, RH10 9LW, UK

declare under our sole responsibility, as manufacturer and person within the EU authorised to assemble the technical file, that the product(s)

18B4B Vapour Booster Pumps

| | | |
|-------------|-------------|-------------|
| B065-10-xxx | B065-20-xxx | B065-30-xxx |
| B065-11-xxx | B065-21-xxx | B065-31-xxx |
| B065-12-xxx | B065-22-xxx | B065-32-xxx |
| B065-13-xxx | B065-23-xxx | B065-33-xxx |

xxx = 200, 220, 240, 380, 440, 480

to which this declaration relates is in conformity with the following standard(s) or other normative document(s)

EN1012-2:1996, A1: 2009 Compressors and Vacuum Pumps. Safety Requirements.
Vacuum Pumps
EN60204-1: 2006 Safety of Machinery. Electrical Equipment of Machines.
+ A1: 2009 General Requirements

and fulfils all the relevant provisions of

2006/95/EC Low Voltage Directive
2004/108/EC Electromagnetic Compatibility (EMC) Directive

Note: This declaration covers all product serial numbers from the date this Declaration was signed onwards.

Peter Meares, Technical Support Manager, Industrial and
Chemical pumps

02.11.2010

Date and Place

This product has been manufactured under a quality system registered to ISO9001

Contents

| Section | Page |
|---|-----------|
| 1 Introduction | 1 |
| 1.1 Scope and definitions | 1 |
| 1.2 Description | 1 |
| 1.3 Construction | 2 |
| 1.4 Principle of operation | 2 |
| 1.5 Over-temperature protection | 3 |
| 1.5.1 Cooling-fail thermal snap-switches | 3 |
| 1.5.2 Boiler-protection thermal snap-switch | 3 |
| 1.6 Low fluid level protection (optional) | 3 |
| 1.7 Temperature indication (optional) | 3 |
| 1.8 Operation with high ambient humidity | 3 |
| 2 Technical data | 7 |
| 2.1 Operating and storage conditions | 7 |
| 2.2 Performance | 7 |
| 2.3 Mechanical data | 8 |
| 2.4 Pump fluid data | 8 |
| 2.5 Cooling-water data | 8 |
| 2.6 Electrical data | 9 |
| 2.7 Construction materials | 9 |
| 2.8 Pump Item Numbers | 10 |
| 3 Installation | 15 |
| 3.1 Safety | 15 |
| 3.2 Unpack and inspect | 15 |
| 3.3 Locate the pump | 16 |
| 3.3.1 General requirements | 16 |
| 3.3.2 Installation on a vacuum system | 16 |
| 3.3.3 Free-standing installation | 17 |
| 3.4 Vacuum connections | 17 |
| 3.4.1 System design | 17 |
| 3.4.2 Connect the pump inlet | 18 |
| 3.4.3 Connect the pump outlet | 18 |
| 3.5 Cooling-water connections | 19 |
| 3.6 Pump fluid drain connection (optional) | 20 |
| 3.7 Connect the electrical supply | 20 |
| 3.7.1 Electrical safety | 20 |
| 3.7.2 Connect the supply to the pump | 21 |
| 3.8 Connect the thermal snap-switches | 25 |
| 3.8.1 Connect the cooling-fail thermal snap-switches | 25 |
| 3.8.2 Connect the boiler protection thermal snap-switch | 25 |
| 3.9 Connect the optional Pt100 temperature probe (if fitted) | 25 |
| 3.10 Leak test the system | 26 |
| 3.11 Fill the pump with fluid | 26 |
| 3.11.1 Safety of vapour pump fluids | 26 |
| 3.11.2 Recommended pump fluids | 27 |
| 3.12 Filling procedure | 27 |
| 3.12.1 Introduction | 27 |
| 3.12.2 General filling procedure | 27 |
| 3.12.3 Filling procedure for adjustment of the fluid low level switch | 29 |
| 3.13 Connect the optional fluid low level switch (if fitted) | 29 |

gea/017/10/10

| | | |
|----------|---|-----------|
| 4 | Operation | 31 |
| 4.1 | Introduction | 31 |
| 4.2 | Check the insulation resistance of the heaters | 31 |
| 4.3 | Start-up | 32 |
| 4.4 | Rough pumping | 32 |
| 4.5 | Adjust the boiler protection thermal snap-switch (if necessary) | 33 |
| 4.6 | Re-admission of air to your vacuum system | 34 |
| 4.7 | Re-evacuation of your vacuum system | 34 |
| 4.8 | Shut-down | 34 |
| 5 | Maintenance | 37 |
| 5.1 | Safety | 37 |
| 5.2 | Tools and equipment required | 37 |
| 5.3 | Maintenance plan | 38 |
| 5.4 | Check the pump fluid-level | 38 |
| 5.5 | Inspect the pump fluid (and drain if necessary) | 38 |
| 5.6 | Clean and inspect the pump | 39 |
| 5.6.1 | Introduction | 39 |
| 5.6.2 | Dismantle the pump | 39 |
| 5.6.3 | Clean the main pump components | 40 |
| 5.6.4 | Clean the interior components | 41 |
| 5.6.5 | Clean the boiler and fluid return pipes | 41 |
| 5.6.6 | Reassemble the pump | 41 |
| 5.6.7 | Prepare the pump for operation | 42 |
| 5.7 | Clean the radiation shield | 43 |
| 5.8 | Replace a pump heater | 43 |
| 5.8.1 | Prepare the pump | 43 |
| 5.8.2 | Identify and remove the defective heater | 44 |
| 5.8.3 | Assemble and fit the new heater | 46 |
| 5.8.4 | Reassemble the pump | 46 |
| 5.9 | Check the heater clamp plate and retaining nuts | 47 |
| 5.10 | Clean the cooling-coil | 47 |
| 5.11 | Fault finding | 47 |
| 6 | Storage and disposal | 49 |
| 6.1 | Storage | 49 |
| 6.2 | Disposal | 49 |
| 7 | Service, spares and accessories | 51 |
| 7.1 | Introduction | 51 |
| 7.2 | Service | 51 |
| 7.3 | Spares | 51 |
| 7.4 | Accessories | 51 |
| | Index | 53 |

For return of equipment, complete the HS Forms at the end of this manual.

Illustrations

| Figure | | Page |
|--------|--|------|
| 1 | Part-sectional view of the 18B4B pump | 5 |
| 2 | Typical performance curves | 11 |
| 3 | Dimensions (mm) | 13 |
| 4 | Heater wiring connections | 21 |
| 5 | Terminal block | 22 |
| 6 | Terminal block links for Star connections | 22 |
| 7 | Star connection wiring diagram | 23 |
| 8 | Terminal block links for Delta connections | 23 |
| 9 | Delta connection wiring diagram | 23 |
| 10 | Recommended control circuit | 24 |
| 11 | Adjust the boiler protection thermal snap-switch | 33 |
| 12 | Typical pumping system | 35 |
| 13 | Replace a heater | 45 |

Tables

| Table | | Page |
|-------|---|------|
| 1 | Operating and storage conditions | 7 |
| 2 | Performance data | 7 |
| 3 | Mechanical data | 8 |
| 4 | Pump fluid data | 8 |
| 5 | Cooling-water data | 8 |
| 6 | Electrical data | 9 |
| 7 | Construction materials | 9 |
| 8 | Pump Item Numbers | 10 |
| 9 | Checklist of items | 15 |
| 10 | Vapour pump fluid thermal breakdown | 28 |
| 11 | Maintenance plan | 38 |
| 12 | Fault finding | 47 |
| 13 | 18B4B accessories | 51 |
| 14 | 18B4B pump spares | 52 |

Supplementary publications

Publication title

Publication number

iTEMP PCP TMT 181 Temperature head transmitter
 liquiphant S FTL70, FTL71 Level Limit Switch
 liquiphant M FTL 51 High Pressure Sliding Sleeve

KA 141R/09/a3/07.02 51004624
 KA 172F/00/a6/04.03 52009621
 KA 153F/00/a6/12.99 52004587

Note: The above manufacturer's instructions will only be provided with pumps supplied fitted with the corresponding option(s).

Associated publications

Publication title

Publication number

Application Note: Operation of diffusion pumps in environments with high ambient humidity

P400-50-000

Trademark credits

Fomblin[®] is a registered trademark of Solvey Solexis

Apiezon[®] is a registered trademark of M & I Materials, UK

1 Introduction

1.1 Scope and definitions

This manual provides installation, operation and maintenance instructions for the Edwards 18B4B Vapour Booster Pumps. You must use the pumps as specified in this manual.

Read this manual before you install and operate your pump. Important safety information is highlighted as **WARNING** and **CAUTION** instructions; you must obey these instructions. The use of **WARNINGS** and **CAUTIONS** is defined below.



WARNING

Warnings are given where failure to observe the instruction could result in injury or death to people.

CAUTION

Cautions are given where failure to observe the instruction could result in damage to the equipment, associated equipment and process.

In accordance with the recommendations of IEC1010, the following warning symbols may appear on the pump or its accessories:



Warning - refer to accompanying documentation.



Warning - risk of electric shock.



Warning - hot surfaces.

The units used throughout this manual conform to the SI international system of units of measurement.

The pump identification and rating plate ([Figure 3](#), item 12) provides specific details about the pump, including: pump type; part number and serial number; name and address of manufacturer; and so on.

1.2 Description

The 18B4B pumps are high performance vapour booster pumps, and have pumping speeds of up to 4000 l s^{-1} .

The pumps are rugged and reliable and have high performance even with relatively high backing pressures.

Three versions of 18B4B pumps are available, with different inlet and outlet flanges: refer to [Section 2.8](#).

1.3 Construction

Refer to [Figure 1](#) which shows a part-sectional view of the 18B4B pump. The pump has:

- A vertical top cone assembly (45) which incorporates the three diffusion pump stages (42, 6 and 5).
- A horizontal side cone assembly (14).
- A boiler (33), which forms part of the base of the pump.
- A 'T' piece (38), which connects the top cone (45), the side cone (14) and the boiler (33).
- A vertical backing condenser (17), which incorporates a baffle assembly (18).

The diffusion pumping jet stages have top (5), second stage (6) and lower (42) vapour tubes, each of which has a jet cap (47, 44, 43). The top jet cap is covered by a guard ring (2), which minimises the backstreaming of pump fluid.

The lower vapour tube is bolted to the ejector stage 'T' piece (38), and the 'T' piece is bolted to the boiler assembly (33), through flanges to allow easy access for cleaning.

The ejector nozzle (8) is housed in the 'T' piece (38), which is bolted to the side cone (14) into which the ejector discharges. The side cone ends in a vertical backing condenser (17).

The pump fluid is heated and vaporised by electric heaters (27). There are three heaters in the pump, rated the same for all voltage variants. The boiler (33) has a dipstick/fluid filler connection (21) and a fluid drain connection (29).

The electrical supply cables from the heaters are connected into a terminal box (31) on the base of the pump, for ease of connection to your electrical supply.

The pump boiler assembly (33) has a cleaning port cover (10). You can remove this cover and use the cleaning port to remove any residue build up from the inside of the boiler. You should regularly clean the boiler, to maintain the pump performance at its optimum level. A radiation shield (22) underneath the heaters reflects heat from the underside of the heaters (27) to the boiler, and so increases the efficiency of the pump.

The pump is cooled by water, which flows through copper cooling-coils (13, 19, 41) wound around the top cone, the side cone and the backing condenser. The cooling couplings (36, 40) connect these coils together, to form a single cooling circuit around the pump.

The pump can be supplied with one or both of the following optional items:

- A fluid low level switch (12): see [Section 1.6](#).
- A Pt100 temperature probe (30): see [Section 1.7](#).

1.4 Principle of operation

Refer to [Figure 1](#). Pump fluid is heated in the boiler (33) to produce a vapour, which passes up through the interior of the diffusion pumping stages (42, 6, 5) and emerges from the gaps in the jet caps (43, 44, 47) as high velocity vapour streams. The vapour streams condense on the cooled walls of the top cone (45) and the side (ejector) cone (11), then drain into the boiler (33) for recirculation.

A portion of system gas which arrives at the pump inlet (1), is trapped in the vapour stream from the first stage jet cap (47). The gases are compressed and transferred to the next stage. The gases then pass through the ejector nozzle (8) and into the backing condenser (17) where they are removed (through the outlet, 16) by your backing pump.

The cooled surface of the guard ring (2) above the top jet cap (47) traps and condenses pump fluid vapour and minimises any backstreaming of pump fluid vapour into your vacuum system.

1.5 Over-temperature protection

1.5.1 Cooling-fail thermal snap-switches

Refer to [Figure 1](#). The pump has two cooling-fail thermal snap-switches (7, 9) on the cooling-coils. These snap-switches protect the pump against damage due to failure of the cooling-water supply.

Both snap-switches have normally closed contacts that will open if the temperature of the cooling coils increases above 46 °C. The snap-switches will reset automatically when the pump cools down.

You must configure the snap-switches to switch off the electrical supply to the pump heaters when the snap-switch contacts open. You must also interlock the snap-switches so that the pump cannot automatically restart after the snap-switch contacts have opened and the pump has then cooled again, until the problem has been rectified.

1.5.2 Boiler-protection thermal snap-switch

The pump has a boiler protection thermal snap-switch ([Figure 3](#), item 20) fitted to the wall of the boiler. The snap-switch protects the pump against damage due to a low level of pump fluid, which causes the boiler temperature to rise.

As supplied, the snap-switch contacts will open when the boiler wall temperature reaches 250 °C.

You must configure the snap-switch to switch off the electrical supply to the pump heaters when the snap-switch contacts open. You must also interlock the snap-switch so that the pump cannot automatically restart after the snap-switch contacts have opened and the pump has then cooled again, until the problem has been rectified.

1.6 Low fluid level protection (optional)

Your pump may be supplied with an optional fluid low level switch ([Figure 1](#), item 12).

If fitted, this level switch will provide a warning that the fluid level in the pump boiler is low, and that more fluid needs to be added.

As supplied, the level switch is preset to operate when the fluid level in the boiler has fallen to 6 litres.

1.7 Temperature indication (optional)

Your pump may be supplied with an optional Pt100 temperature probe ([Figure 1](#), item 30), fitted to the fluid drain connection.

If fitted, this probe will provide an indication of the temperature of the pump fluid.

1.8 Operation with high ambient humidity

When the pump is switched off, the heaters in the pump will absorb moisture: this will cause a decrease in the insulation resistance of the heaters. If you operate the pump in an environment with high ambient humidity, this may cause the heaters to fail. The rate of moisture absorption (and therefore the time taken for the insulation resistance of the heaters to fall below the recommended value) depends on the ambient humidity and temperature and the length of time that the pump is switched off.

In addition to the recommendations made in later sections of this manual, you can overcome the effect of high ambient humidity if you:

- Configure the electrical installation of the pump for 'soft-start' operation, when the pump is operated with typically 20 to 25% of the nominal supply voltage.
- Install an anti-moisture heater under the base of the pump. Switch on this heater when you switch off the pump.

Detailed information about these recommendations is outside the scope of this manual. If you need more information about the operation of the pump with high ambient humidity, request a copy of our Application Note P400-50-000 from your supplier or Edwards.

Figure 1 - Part sectional view of the 18B4B pump: key

- | | |
|---------------------------------------|--|
| 1. Inlet | 25. Heater retaining nut |
| 2. Guard ring | 26. Heater cover |
| 3. Inlet 'O' ring | 27. Heater |
| 4. Cooling-water inlet | 28. Earth (ground) stud |
| 5. Top vapour tube | 29. Fluid drain plug |
| 6. Second stage vapour tube | 30. Pt100 temperature probe (optional) |
| 7. Cooling-fail thermal snap-switch | 31. Terminal box |
| 8. Ejector nozzle | 32. Boiler base |
| 9. Cooling-fail thermal snap-switch | 33. Boiler |
| 10. Cleaning port cover and gasket | 34. Jet stack fluid return pipe |
| 11. Cleaning port access lid | 35. Tie-rod |
| 12. Fluid low level switch (optional) | 36. Cooling coupling |
| 13. Cooling-coil | 37. 'T' piece 'O' ring |
| 14. Side cone assembly | 38. 'T' piece |
| 15. Cooling-water outlet | 39. Jet gasket |
| 16. Outlet (backing connection) | 40. Cooling coupling |
| 17. Backing condenser | 41. Cooling-coil |
| 18. Baffle | 42. Lower vapour tube |
| 19. Cooling-coil | 43. Lower jet cap |
| 20. Condenser fluid return pipe | 44. Second stage jet cap |
| 21. Dipstick | 45. Top cone assembly |
| 22. Heater radiation shield | 46. Locating pin |
| 23. Mounting feet | 47. Top jet cap |
| 24. Clamp plate | 48. Setting dimension: 1.6 mm ¹ |

¹ This is the setting dimension for AP201 fluid. This dimension may differ if you use a different fluid: refer to Section 5.6.6.

Figure 1 - Part-sectional view of the 18B4B pump

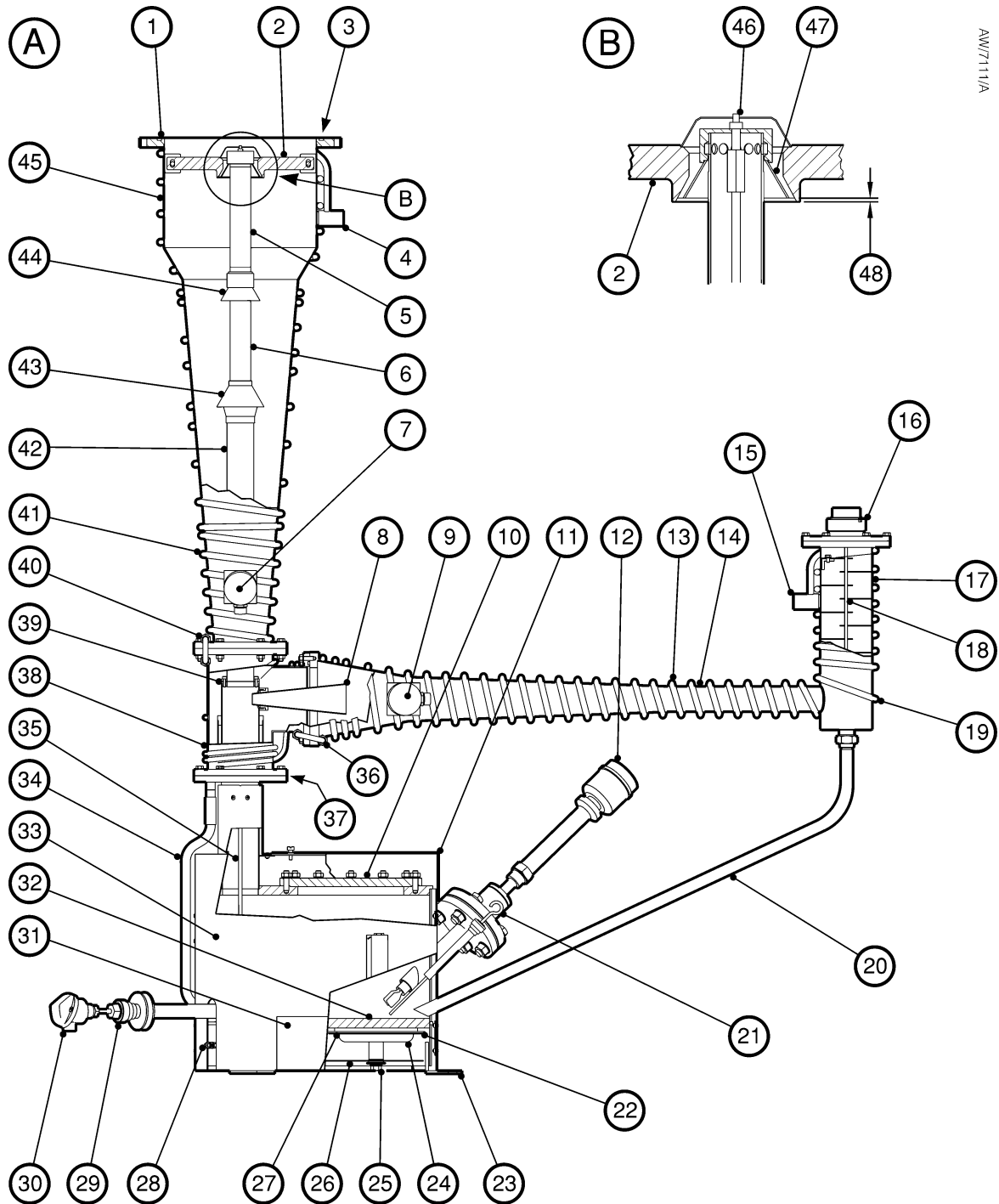

AM/7111/A

This page has been intentionally left blank.

2 Technical data

2.1 Operating and storage conditions

Table 1 - Operating and storage conditions

| | |
|--|------------------------------------|
| Maximum ambient operating temperature | 40 °C |
| Typical surface temperature during operation | |
| Jet stage cone | 30 °C |
| Boiler | 200 °C |
| Maximum surface temperature during operation | |
| Jet stage cone | 55 °C |
| Under covers/below the pump | 250 °C |
| Minimum backing pump displacement | 190 m ³ h ⁻¹ |
| Recommended Edwards backing pump | GV260M, E1M275 |

2.2 Performance

Note: The performance data in Table 2 and in Figure 2 is for use of the pump with Apiezon AP201 fluid.

The pumping speeds and throughput specified below and shown in Figure 2 were calculated from measurements made with partial pressure gauges. If total pressure gauges are used, the calculated values for pumping speeds are approximately 10% lower. This is because partial pressure gauges do not measure the pressure added to the system by condensable gases.

We do not give absolute values for the ultimate pressure of the pump. The ultimate pressure depends on the fluid used in the pump, the leak tightness of the system, outgassing from surfaces, and the use of cold traps.

Table 2 - Performance data

| | |
|--|---|
| Performance curves | See Figure 2 |
| Maximum system pressure (absolute) | 1.3 bar absolute, 1.3 x 10 ⁵ Pa |
| Critical backing pressure | 2 to 2.6 mbar, 2 to 2.6 x 10 ² Pa |
| Pumping speed (ISO) | |
| Air | 4000 l s ⁻¹ |
| Hydrogen | 6000 l s ⁻¹ |
| Maximum throughput (air) | 100 mbar l s ⁻¹ , 1 x 10 ⁴ Pa l s ⁻¹ |
| Backstreaming rate at ultimate vacuum | 0.7 mg cm ⁻² min ⁻¹ |
| Fluid loss at 1 x 10 ⁻¹ mbar, 10 Pa | 10 g h ⁻¹ |
| Warm-up time to maximum throughput | 60 min |
| Cool-down time (to approximately 100 °C) | 120 min |

2.3 Mechanical data

Table 3 - Mechanical data

| | |
|---|---|
| Dimensions | See Figure 3 |
| Mass | |
| Complete pump (without fluid) | 165 kg |
| Complete pump (with full fluid charge) | 175 kg |
| Jet stage cone | 40 kg |
| Side cone assembly | 20 kg |
| Cleaning port cover * | 8 kg |
| Heater assembly and terminal box * | 10 kg |
| Boiler assembly (including * items above) | 105 kg |
| Maximum stability angle | 10° |
| Inlet flange | EHVI, ANSI12 or ISO320: see Figure 3 |
| Outlet flange | 2 inch union, ANSI14 or ISO160: see Figure 3 |
| Cooling-water connections | 1/2 inch BSP female (with 1/2 inch NPT male adaptors) |

2.4 Pump fluid data

Note: A Edwards Material Safety Data Sheet for the fluid specified below is available on request.

Table 4 - Pump fluid data

| | |
|------------------------|---------------|
| Recommended fluid type | Apiezon AP201 |
| Fluid charge | |
| Nominal | 10 l |
| Minimum | 6 l |
| Fluid data (for AP201) | |
| Flash point | 196 °C |
| Auto-ignition point | 305 °C |
| Molecular weight | 310 |

2.5 Cooling-water data

Table 5 - Cooling-water data

| | |
|---|---|
| Maximum allowed water outlet temperature | 35 °C |
| Minimum cooling-water flow rate (at 25 °C) | 375 l h ⁻¹ |
| Pressure differential across supply and return (with minimum recommended flow rate) | 1.3 bar gauge, 2.3 x 10 ⁵ Pa |

2.6 Electrical data

Table 6 - Electrical data

| | |
|---|-------------------------------------|
| Heater rating | 2 kW |
| Nominal heater power (3 heaters) | 6 kW |
| Electrical supply | |
| Nominal 200 V supply | 200 - 210 V, 50/60 Hz, three-phase |
| Nominal 220 V supply | 220 - 230 V, 50/60 Hz, three-phase |
| Nominal 240 V supply | 240 - 250 V, 50/60 Hz, three-phase |
| Nominal 380 V supply | 380 - 400 V, 50/60 Hz, three-phase |
| Nominal 440 V supply | 415 - 440 V, 50/60 Hz, three-phase |
| Nominal 480 V supply | 460 - 480 V, 50/60 Hz, three-phase |
| Over-current protection settings (on full heat) | |
| 200 V, 50/60 Hz | 20 A |
| 220 V, 50/60 Hz | 18 A |
| 240 V, 50/60 Hz | 16 A |
| 380 V, 50/60 Hz | 11 A |
| 440 V, 50/60 Hz | 10 A |
| 480 V, 50/60 Hz | 9 A |
| Cooling-fail thermal snap-switch rating | 6.3 A at 250 V a.c. |
| Boiler protection thermal snap-switch rating | 5 A at 240 V a.c. |
| Maximum interlock control voltage | 277 Vac |
| Recommended control voltage | 24 Vac |
| Pt100 temperature probe (optional) | |
| Output (proportional to measurement range) | 4 to 20 mA |
| Measurement range | 0 to 300 °C |
| Power supply voltage | 8 to 35 V d.c. |
| Fluid low level switch (optional) | |
| Power supply voltage | 19 to 253 V a.c. or 19 to 55 V d.c. |
| Relay contacts maximum voltage | 253 V a.c., 30 V d.c. |
| Relay contacts maximum current | 6 A |

2.7 Construction materials

Table 7 - Construction materials

| | |
|-----------------------------|---------------------------------------|
| Pump body | Nickel plated/painted mild steel |
| Covers | Anodised aluminium |
| Water cooling coils | High conductivity copper |
| Inlet and backing 'O' rings | Fluoroelastomer |
| Internal pump 'O' rings | Fluoroelastomer |
| Jet stack gasket | Aramid fibre in nitrile rubber binder |
| Boiler port gasket | Carbon fibre in nitrile rubber binder |

2.8 Pump Item Numbers

Table 8 - Pump Item Numbers

| Pump voltage and options | Inlet | | |
|---|-------------|-------------|-------------|
| | EHVI | ANSI | ISO |
| 18B4B pump | | | |
| 200 V | B065-10-200 | B065-20-200 | B065-30-200 |
| 220 V | B065-10-220 | B065-20-220 | B065-30-220 |
| 240 V | B065-10-240 | B065-20-240 | B065-30-240 |
| 380 V | B065-10-380 | B065-20-380 | B065-30-380 |
| 440 V | B065-10-440 | B065-20-440 | B065-30-440 |
| 480 V | B065-10-480 | B065-20-480 | B065-30-480 |
| 18B4B pump, with Pt100 temperature probe | | | |
| 200 V | B065-11-200 | B065-21-200 | B065-31-200 |
| 220 V | B065-11-220 | B065-21-220 | B065-31-220 |
| 240 V | B065-11-240 | B065-21-240 | B065-31-240 |
| 380 V | B065-11-380 | B065-21-380 | B065-31-380 |
| 440 V | B065-11-440 | B065-21-440 | B065-31-440 |
| 480 V | B065-11-480 | B065-21-480 | B065-31-480 |
| 18B4B pump, with fluid low level switch | | | |
| 200 V | B065-12-200 | B065-22-200 | B065-32-200 |
| 220 V | B065-12-220 | B065-22-220 | B065-32-220 |
| 240 V | B065-12-240 | B065-22-240 | B065-32-240 |
| 380 V | B065-12-380 | B065-22-380 | B065-32-380 |
| 440 V | B065-12-440 | B065-22-440 | B065-32-440 |
| 480 V | B065-12-480 | B065-22-480 | B065-32-480 |
| 18B4B pump, with Pt100 and fluid low level switch | | | |
| 200 V | B065-13-200 | B065-23-200 | B065-33-200 |
| 220 V | B065-13-220 | B065-23-220 | B065-33-220 |
| 240 V | B065-13-240 | B065-23-240 | B065-33-240 |
| 380 V | B065-13-380 | B065-23-380 | B065-33-380 |
| 440 V | B065-13-440 | B065-23-440 | B065-33-440 |
| 480 V | B065-13-480 | B065-23-480 | B065-33-480 |

Figure 2 - Typical performance curves

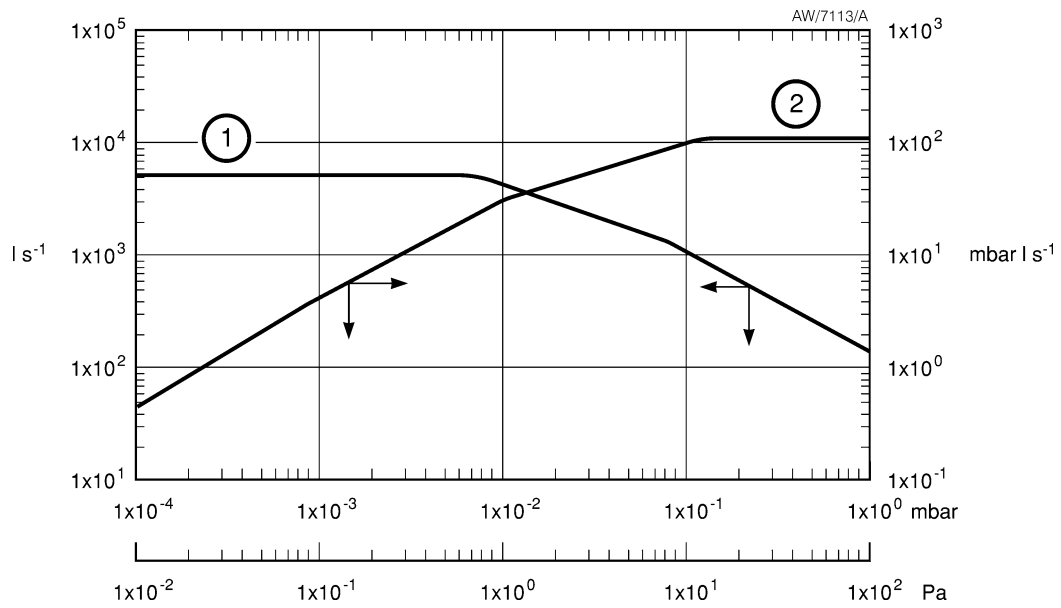

1. Pumping speed ($l s^{-1}$) against inlet pressure (mbar/Pa) for nitrogen
2. Throughput ($mbar l s^{-1}$) against inlet pressure (mbar/Pa) for nitrogen

Figure 3 - Dimensions (mm): key

1. Inlet
2. Cooling-water inlet
3. Outlet
4. Cooling-water outlet
5. Cooling-fail thermal snap-switches
6. Clearance required to remove heaters
7. Fluid low level switch (optional)
8. Electrical box
9. Earth (ground) stud
10. Pt100 temperature probe (optional)
11. Fluid drain connection
12. Identification and rating plate
13. Hot surfaces: temperatures below this line can reach 250 °C
14. Fixing holes (3 off): Ø17.5 on 549 PCD
15. ISO inlet
16. EHVI inlet
17. ANSI inlet
18. ANSI outlet (8 holes Ø19.2 on 190.5 PCD)
19. ISO outlet (8 holes Ø11.2 on 200 PCD)
20. EHVI outlet (2 inch union nut and tailpiece, counter-bored Ø54.1-54.18 x 19.4, 20.2 deep)
21. Boiler protection thermal snap-switch
22. Fixing holes:
 - 12 holes Ø14 on 395 PCD (ISO inlet)
 - 12 holes Ø25.4 on 431.8 PCD (ANSI inlet)
 - 8 holes Ø11 on 387.4 PCD (EHVI inlet)

| | ØA | ØB | C |
|------|-------|-------|-----|
| ANSI | 482.6 | 228.6 | 807 |
| ISO | 425 | 225 | 807 |
| EHVI | 406 | 178 | 810 |

Figure 3 - Dimensions (mm)

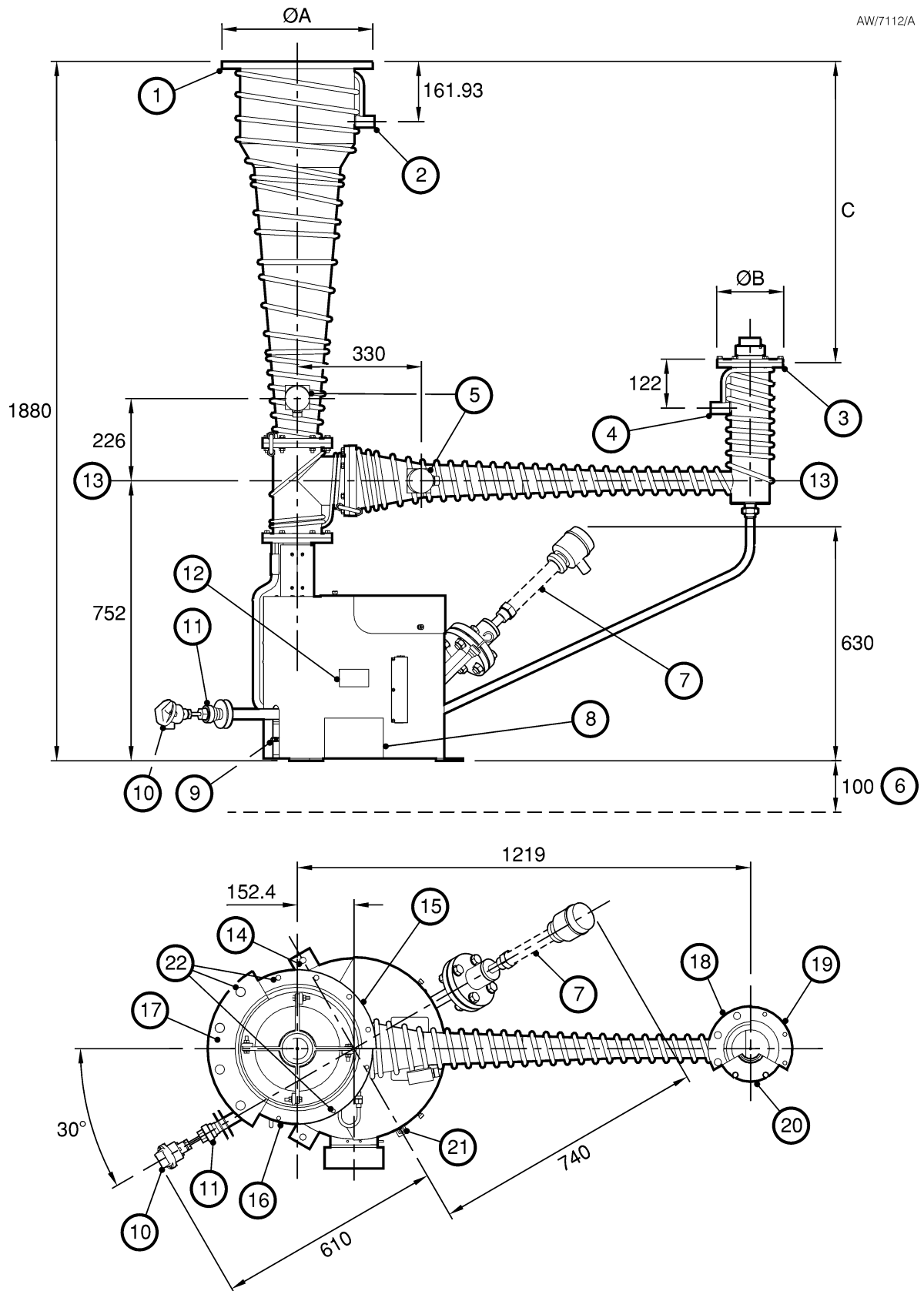

This page has been intentionally left blank.

3 Installation

3.1 Safety



WARNING

Obey the safety instructions given below and take note of appropriate precautions. If you do not, you can cause injury to people and damage to equipment.

- A suitably trained and supervised technician must install the pump.
- Isolate the other components in the vacuum system from the electrical supply before you start work.
- Use suitable lifting equipment when you move the pump.
- Ensure that the products handled by the pumping system are compatible with the materials of construction of the pump (see [Section 2.7](#)). If you have any doubts about the compatibility, contact your supplier or Edwards for advice.
- Do not use solvents to clean 'O' rings.
- Ensure that the installation technician is familiar with the safety precautions which relate to pump fluid and to the products handled by the pumping system. Wear the appropriate safety clothing when you come into contact with pump fluid or contaminated components. Dismantle and clean contaminated components inside a fume cupboard.
- Disconnect the other components of the vacuum system from the electrical supply so that they cannot be operated accidentally.
- Vent and purge the vacuum system with nitrogen for 15 minutes before you start installation work.

3.2 Unpack and inspect

1. Remove all packing materials and protective covers and check the pump. If the pump is damaged, notify your supplier and the carrier in writing within three days; state the Item Number of the pump together with your order number and your supplier's invoice number. Retain all packing materials for inspection. Do not use the pump if it is damaged.
2. Check that you have received the items listed in [Table 9](#). If any item is missing, notify your supplier in writing within three days.

Table 9 - Checklist of items

| Quantity | Description | Check (✓) |
|----------|--|--------------------------|
| 1 | 18B4B pump | <input type="checkbox"/> |
| 1 | Fitting pack | <input type="checkbox"/> |
| 1 | Pt100 temperature probe instructions * | <input type="checkbox"/> |
| 2 | Fluid low level switch & sleeve instructions * | <input type="checkbox"/> |

* Only supplied if the corresponding optional device is fitted: refer to the list of Supplementary Publications at the end of the contents list.

3. Check that your electrical supply voltage corresponds to the voltage stated on the pump identification and rating plate ([Figure 3](#), item 11). If the pump is not suitable for use with your electrical supply, do not continue to install and use the pump.

If the pump is not to be used immediately, refit the protective covers. Store the pump in suitable conditions, as described in [Section 6.1](#).

3.3 Locate the pump



WARNING

Use suitable lifting equipment to move the pump. If you do not, you can injure yourself or damage the pump. Refer to [Section 2.3](#) for the mass of the pump.



WARNING

You must remove the foam heater support from the base of the pump. If you do not, the heater support may catch fire when you operate the pump.



WARNING

During operation, surfaces of the pump are very hot and can cause injury to people and damage to equipment. Install the pump so that people cannot accidentally touch hot surfaces of the pump.

CAUTION

Ensure that you do not damage the terminal box when you locate the pump in its operating location.

CAUTION

Ensure that there is a clearance of at least 70 mm between the pump mounting feet and the nearest object/surface. Avoid contact between the pump and combustible materials, plastic materials and electrical cables. Surfaces of the pump are very hot and can cause damage to equipment.

3.3.1 General requirements

You must operate the pump with its inlet-flange horizontal and at the top.

If the pump will be free-standing, you must support the backing pipeline to stabilize the pump.

Pipelines connected to the pump inlet and outlet must be self-supporting. Where this is not possible, ensure that the pipelines impose as small a load as possible on the inlet and outlet flanges.

Locate the pump at a practical distance from suitable electrical and cooling-water supplies and so that you can easily access the dipstick and other components.

Ensure that you leave sufficient access space ([Figure 3](#), item 6) under the pump, so that you can replace a heater without having to lift the pump.

Note that surfaces of the pump can get very hot during operation. Ensure that people cannot accidentally touch the hot surfaces of the pump. If necessary, fit guard rails.

3.3.2 Installation on a vacuum system

Note: *The centre of mass of the pump on its pallet is not at the centre of the pallet itself.*

1. Refer to [Figure 1](#). Inspect the pump inlet (1) and outlet (16), 'O' rings and 'O' ring grooves and refinish if necessary: refer to [Section 3.4.1](#).
2. Use a wide-track pallet truck or fork-lift to carefully and slowly move the pump (on its pallet) under its required operating location. Ensure that the pump does not topple when you move it.
3. Use the pallet truck or fork-lift to raise the pump until the inlet locates onto your vacuum system flange, then secure the pump inlet to the vacuum system flange: refer to [Section 3.4.2](#).

4. Undo and remove the bolts, nuts and washers (fitted through the fixing holes: [Figure 3](#), items 13) which secure the pump to the pallet. Retain the bolts, nuts and washers for future use (for example, if you need to move the pump for maintenance).
5. Lower the pallet clear of the pump. Retain the pallet for future use.
6. Ensure that the foam heater support remains attached to the pallet. If necessary, remove the heater support from the pump.

3.3.3 Free-standing installation

Note: The centre of mass of the pump on its pallet is not at the centre of the pallet itself.

1. Use a wide-track pallet truck or fork-lift to carefully and slowly move the pump (on its pallet) close to its required operating location. Ensure that the pump does not topple when you move it.
2. Undo and remove the bolts, nuts and washers (fitted through the fixing holes: [Figure 3](#), items 13) which secure the pump to the pallet. Retain the bolts, nuts and washers for future use (for example, if you need to move the pump for maintenance).
3. Attach suitable slings to the pump under the inlet flange ([Figure 1](#), item 1), then attach suitable lifting equipment (such as a crane or hoist) to the slings.
4. Use the lifting equipment to lift the pump from its pallet. Retain the pallet for future use.
5. Ensure that the foam heater support remains attached to the pallet. If necessary, remove the heater support from the pump.
6. Use the lifting equipment to move the pump close to its required operating location, then carefully lower the pump into its operating location. Take care not to damage the terminal box when you lower the pump.
7. Disconnect the lifting equipment from the pump.
8. Fix suitable bolts through the fixing holes ([Figure 3](#), item 13) on each of the three mounting feet to secure the pump in position.

3.4 Vacuum connections

3.4.1 System design



WARNING

You must fit a backing pressure-interlock.

Consider the following points when you design your system:

- On all applications, you must fit a pressure interlock to the backing pipeline to switch off the electrical supply to the pump heaters if the pressure in the pipeline rises to the critical backing pressure. If you do not fit a pressure interlock and the pressure in the backing pipeline rises to the critical backing pressure, fluid will backstream into the vacuum system and thermal breakdown of the pump fluid may occur (refer to [Section 3.11.1](#)). Note that if you have a suitable backing pressure gauge, you may be able to use the gauge to provide the necessary pressure signal for the pressure interlock.
- Connecting pipelines should be as short as possible and have the largest possible diameter.
- You must be able to isolate the pump inlet and outlet from the atmosphere and from your vacuum system.
- You must be able to vent the pump to atmosphere through the backing pipeline or the pump inlet. (You must not vent the pump through the boiler).

- Incorporate flexible pipelines in the backing pipeline to reduce the transmission of vibration and to prevent loading of coupling joints. If you use flexible pipelines, you must ensure that you use pipelines which have a maximum pressure rating which is greater than the highest pressure that can be generated in your system. We recommend that you use Edwards flexible pipelines.
- Before you connect the pump to your vacuum system: inspect the inlet and outlet flange sealing faces and ensure that they are free of scratches; if necessary, refinish the sealing faces; clean the flanges with a suitable cleaning solution.

3.4.2 Connect the pump inlet

Notes: 1. Some of the 'O' rings necessary to install the pump are supplied in the fitting pack.

2. If the pump is not free-standing, you will have connected the pump inlet in [Section 3.3.2](#).

Refer to [Figure 1](#). Connect the pump inlet (1) to your vacuum system. When you connect the pump inlet:

- Use the correct number and size of bolts to connect the pump to your vacuum system.
- Use an 'O' ring (3) to seal the connection; clean the 'O' ring and apply a light wipe of pump fluid or vacuum grease to the 'O' ring before you connect the inlet flange. Ensure that the 'O' ring is not twisted.
- The pump is tested with AP201 fluid before delivery. Internal surfaces of the pump are therefore covered with a thin film of AP201 fluid. (Pumps ordered for use with alternative fluids will be tested with the alternative fluid.) Use acetone or another suitable cleaning solution to clean the pump flanges before you connect the pump to your vacuum system.
- We recommend that you fit a combined baffle and isolation valve to the pump (refer to [Section 7.4](#)). A baffle valve minimises the back streaming of pump fluid into your vacuum system. This back streaming is unacceptable in some applications.

3.4.3 Connect the pump outlet



WARNING

Conduct the outlet pipeline to a suitable treatment plant to prevent the discharge of dangerous gases and vapours to the surrounding atmosphere.

Refer to [Figure 1](#). Connect the backing outlet (16) to your backing pipeline.

When you connect the backing outlet:

- For EHVI flange pumps, you may either use a 2 inch union to connect the backing flange, or connect directly to the backing flange.
- Cover all Co-Seals, centring-rings and 'O' rings with a light wipe of pump fluid or vacuum grease before you connect the outlet.
- Adequately support the backing pipeline, to prevent the transmission of stress to the backing connection.

3.5 Cooling-water connections

CAUTION

Make sure the cooling-water flows in the correct direction. If it does not, there will be increased backstreaming and loss of performance, which may have an adverse effect on your process.

CAUTION

Do not fit quick-fit couplings to the pump cooling-water inlet and outlet. Use of these couplings can result in trapped volumes of water.

The minimum cooling water flow given in [Section 2.5](#) is calculated for a 15 °C temperature rise. Thus, with a high water inlet temperature, it may be necessary to increase the flow to maintain the outlet temperature below 35 °C. Do not exceed this temperature, otherwise a thermal snap-switch may operate to switch off the pump, and fluid loss to the backing pipeline will increase.

Use the formula below to calculate the minimum required cooling-water flow for the pump:

$$F = (3600 \times 0.9 \times P_h) / [4200 \times (35 - T_w)]$$

where:

F is the minimum required cooling-water flow (in l h⁻¹).

P_h is the heater power (in W).

T_w is the cooling-water supply temperature (in °C).

Note that:

- 90% of heater input power is transferred to the water supply (the balance is lost as radiant heat from the pump surfaces)
- The cooling-water used must contain no additional additives that may affect its cooling properties.
- The outlet temperature must be no higher than 35 °C.
- The calculated value gives an absolute minimum water flow rate. We recommend that the water flow rate is at least 20% higher than this minimum flow rate.

High cooling-water temperatures should not have any appreciable effect on pump performance except to increase the vapour pressure of the fluid, which will limit the ultimate vacuum that can be obtained.

We recommend that the cooling-water supply is filtered and that a flow indicator is incorporated into the supply system.

Refer to [Figure 1](#). Use a 1/2 inch BSPT connection to connect your cooling-water inlet and return pipelines to the cooling-water inlet (4) and outlet (15) on the pump. Alternatively, if required you can use the 1/2 inch NPT adaptors supplied.

If required, you can remove one of the cooling couplings ([Figure 1](#), items 36 and 40) to divide the cooling-coils into two separate cooling circuits. Cooling in this way provides the best possible performance in terms of ultimate pressure and backstreaming, and limits fluid loss through the condenser. In this configuration:

- The cooling-water inlet for each cooling circuit must be at the top of the inlet cone and the backing condenser.
- The cooling-water return outlet for each cooling circuit must be at the cooling coupling connection.

Maintain the cooling-water inlet temperature as low as possible, preferably below 25 °C. Ensure that the cooling-water flow is satisfactory before you switch the pump heaters on: refer to [Section 4.3](#).

3.6 Pump fluid drain connection (optional)

Note: You cannot connect a fluid drain pipeline to the pump if your pump has a Pt100 temperature probe fitted.

If required, connect a suitable pipeline to the pump fluid drain connection (Figure 1, item 29).

3.7 Connect the electrical supply

3.7.1 Electrical safety



WARNING

A competent electrician must carry out the electrical installation of the pump.



WARNING

Ensure that the electrical installation of the pump conforms with your local and national safety requirements. The pump must be connected to a suitably rated and protected electrical supply and a suitable earth (ground) point.



WARNING

Make the electrical connections as described in this section and in Section 3.7.2. If you do not, the pump may not operate safely, and will not comply with the requirements of BS EN60204-1.

You must use a suitable isolator with an over current trip to connect the electrical supply to the pump. Use a cable of suitable rating for the total heater loading (see Section 2.6).

You must provide adequate strain relief and protection for your cables. We recommend that you use conduit to connect the electrical supply.

The terminal box incorporates a number of cable entry leadthroughs (with 'knock-out' type blanking plates), suitable for use with cable-glands or conduit fittings. Use the most suitable leadthrough(s) for your installation.

As described in Section 1.8, when the pump is switched off, the heaters in the pump will absorb moisture: this will cause a decrease in the insulation resistance of the heaters.

We recommend that you connect the electrical supply to the pump through an RCCB (residual current circuit breaker): the RCCB will operate to disconnect the electrical supply if the insulation resistance of the heaters is too small.

For additional electrical safety:

- Incorporate suitable fuses in your electrical supply.
- If you do not use conduit for the electrical installation, use cable which is heat resistant (up to 200 °C) in case of accidental contact with the pump.
- Fit an emergency stop button, so that you can easily shut down the pump in an emergency.
- Check the earth (ground) resistance of the pump electrical supply before switch on.

Figure 10 shows the recommended control circuit.

3.7.2 Connect the supply to the pump

Connect a 3-phase electrical supply to the pump as described below. Refer to [Figure 4](#), which shows the heater wiring connections. The terminal numbers in [Figure 4](#) are the same as those in [Figure 5](#), which shows the terminal block.

1. Check the type of connection (that is, Delta or Star), then position the terminal block links and connect the electrical supply:
 - For 380-400 V, 415-440 V or 460-480 V Star connection, position the terminal block links as shown in [Figure 6](#) and connect the electrical supply to the heaters as shown in [Figure 7](#).
 - For 200-210 V, 220-230 V or 240-250 V Delta connection, position the terminal block links as shown in [Figure 8](#) and connect the electrical supply to the heaters as shown in [Figure 9](#).
2. Refer to [Figure 13](#). Connect the earth (ground) wire to the main earth (ground) stud in the electrical box (17).
3. Ensure that the earth (ground) wires on the terminal block cover (4) and the electrical box cover (1) are properly secured to the two earth (ground) points on the bottom of the electrical box.

Figure 4 - Heater wiring connections

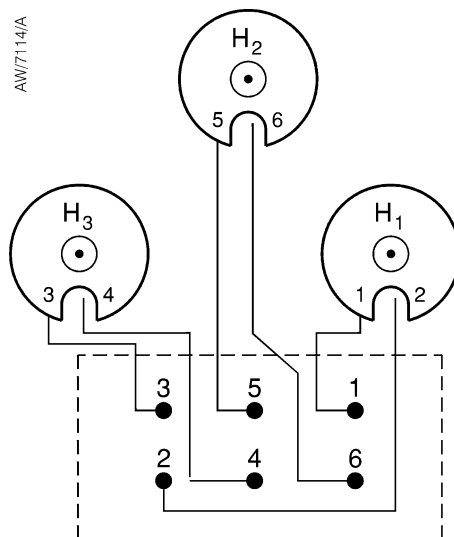
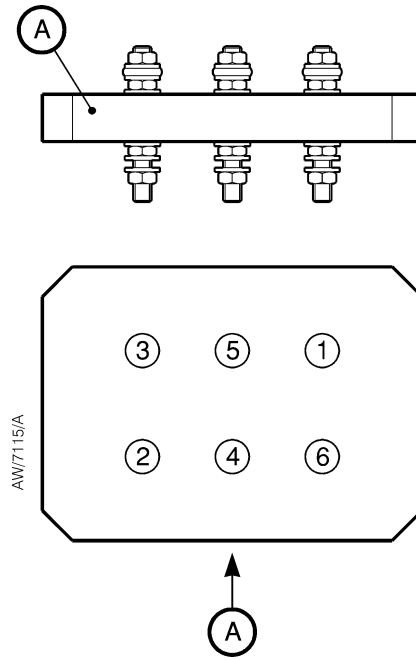

Figure 5 - Terminal block



A. Top edge

Figure 6 - Terminal block links for Star connections

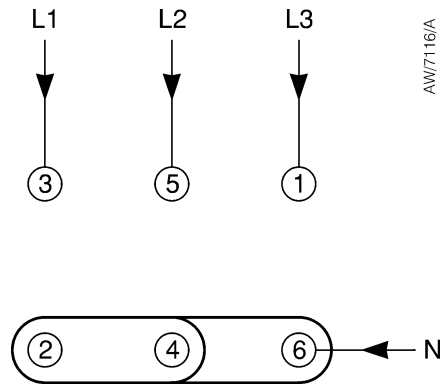

Figure 7 - Star connection wiring diagram

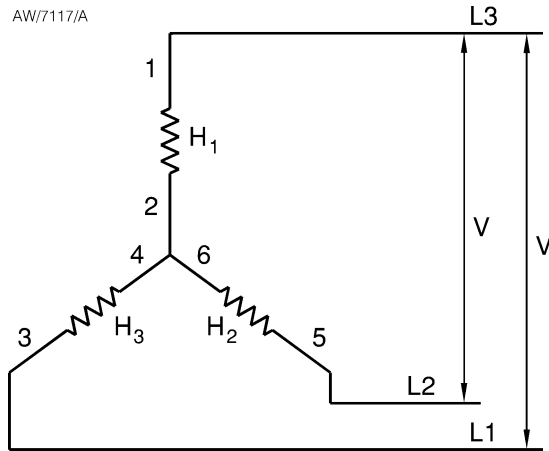

Figure 8 - Terminal block links for Delta connections

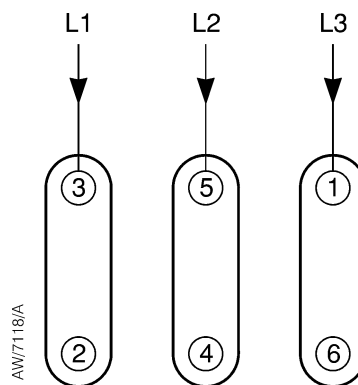

Figure 9 - Delta connection wiring diagram

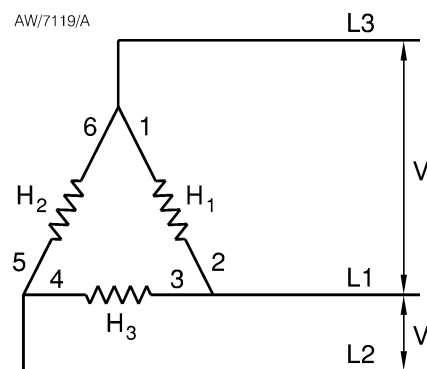
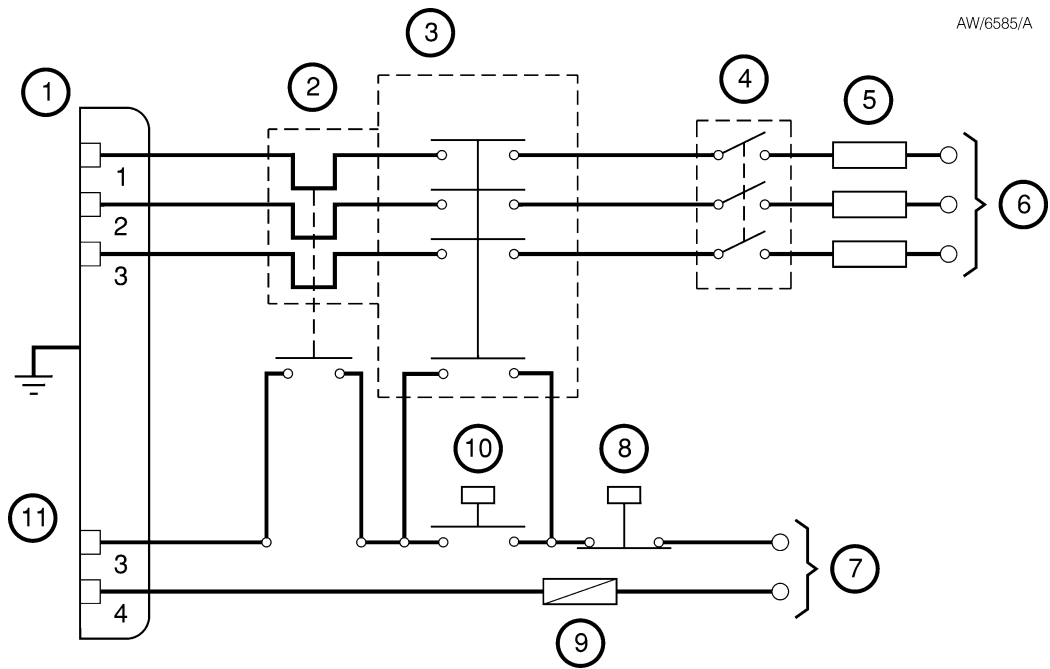

Figure 10 - Recommended control circuit



- | | |
|--------------------------|---|
| 1. Connection to heaters | 7. Control electrical supply |
| 2. Overcurrent trip | 8. Off switch |
| 3. Contactor | 9. Contactor coil |
| 4. Off load isolator | 10. On switch |
| 5. Fuses | 11. Connection to thermal snap-switches |
| 6. Electrical supply | |

3.8 Connect the thermal snap-switches

3.8.1 Connect the cooling-fail thermal snap-switches



WARNING

The thermal snap-switches must be connected to a suitable earth (ground) point.



WARNING

You must connect the thermal snap-switches to your pump control circuit so that the electrical supply to the pump is switched off if either of the thermal snap-switches open. If you do not, the pump may overheat and be damaged and the pump fluid may undergo thermal breakdown.

The cooling-fail thermal snap-switches protect the pump against damage due to failure of the cooling-water supply. If the temperature of the pump cooling circuit increases above the normal operating level, the snap-switch contacts will open.

You must connect the thermal snap-switch contacts to your pump control circuit (see [Figure 10](#)) so that the electrical supply to the pump is switched off if either of the thermal snap-switch contacts open

The thermal snap-switches automatically reset when the temperature of the pump returns to normal. Incorporate an interlock so that the electrical supply to the pump is not automatically restored when the snap-switches reset.

The operating temperature of the cooling-fail thermal snap-switches is preset for use with AP201 pump fluid. If you want to use other fluid types in the pump, contact your supplier or Edwards for advice.

Note: The cooling-fail thermal snap-switches may be wired in series with the boiler protection thermal snap-switch (see [Section 3.8.2](#)).

3.8.2 Connect the boiler protection thermal snap-switch



WARNING

The thermal snap-switch must be connected to a suitable earth (ground) point.



WARNING

You must connect the thermal snap-switch to your pump control circuit so that the electrical supply to the pump is switched off if the thermal snap-switch opens. If you do not, the pump may overheat and the pump fluid may undergo thermal breakdown.

The thermal snap-switch protects the pump against overheating due to a low level of pump fluid in the boiler.

The boiler protection thermal snap-switch can be wired in series with the cooling-fail thermal snap-switches.

You must adjust the boiler protection thermal snap-switch when you first switch on the pump: refer to [Section 4.5](#).

3.9 Connect the optional Pt100 temperature probe (if fitted)

If you have ordered your 18B4B pump with the optional Pt100 temperature probe, the pump will be supplied with the probe fitted as shown in [Figure 1](#), item 30.

Connect the probe to your control or indicator equipment as described in the manufacturer's instructions supplied.

3.10 Leak test the system

After you have installed the pump, leak-test the system before you fill the pump with pump fluid, and seal any leaks found; outgassing from the fluid may give false test results. The pump fluid is viscous at ambient temperatures and may block small leaks.

The level of leak tightness required will depend on the application of your system. You must leak-test the system to ensure the integrity of your vacuum system and its vacuum seals.

3.11 Fill the pump with fluid

3.11.1 Safety of vapour pump fluids



WARNING

Ensure that you comply with the safety recommendations given below when you handle or use pump fluid.

Vapour pump fluids are not dangerous when used in a pump that is operated correctly. But if the pump is operated incorrectly and is allowed to get to very high temperatures, the pump fluid can go through a process of thermal breakdown. The breakdown products which result can be dangerous.

Table 10 gives more information about the thermal breakdown of the different vapour pump fluids. Thermal breakdown is more likely to occur if the breakdown temperature is close to the operating temperature of your pump.

Ensure that you comply with the following general safety recommendations when you handle or use vapour pump fluids:

- Store pump fluids away from heat and naked flames.
- Keep fluid containers closed when not in use.
- Prevent spills and minimise operations that will contaminate the working areas and equipment.
- Use suitable absorbent materials to mop up small spills, and dispose of the materials as described in Section 6.2.
- Keep eyewash bottles filled with water readily available. Use these bottles to immediately flush the eyes if contaminated with pump fluid.
- Minimise exposure to the pump fluid. Wear suitable protective clothing, such as impervious gloves, apron, boots and so on. Avoid prolonged and repeated contact with pump fluid.
- Do not put on heavily contaminated items of clothing or protective equipment until they have been laundered or decontaminated.
- Wash your hands with soap and water before eating or smoking, before using toilet facilities and before leaving work.

3.11.2 Recommended pump fluids



WARNING

Do not use perfluoropolyether (PFPE) pump fluids in the 18B4B pump. The thermal breakdown temperature of PFPE fluids is near to the operating temperature of the pump. The thermal breakdown products of PFPE fluids are very dangerous.

Note: As stated in [Section 3.8](#), the thermal snap-switches fitted to the pump are preset for use with AP201 fluid. If you use a different fluid in the pump, you must adjust the snap-switches.

Choose the best fluid for your application. Take note of the information given in [Table 10](#) about the thermal breakdown temperature and the decomposition products of the various pump fluids.

We recommend that you use Apiezon AP201 fluid in the 18B4B pumps. Please consult Edwards or your supplier if you want to use other fluids.

3.12 Filling procedure

3.12.1 Introduction

The general procedure to fill the pump with fluid is given in [Section 3.12.2](#).

However, if your pump has an optional fluid low level switch, you must use the procedure in [Section 3.12.3](#) to adjust the level switch and fill the pump:

- When you first fill the pump with fluid.
- If the level switch has been removed from the pump, and has then been refitted.
- If you suspect that the level switch needs to be readjusted.

3.12.2 General filling procedure

Use the best fluid for your application. The pump is tested with AP201 pump fluid and will contain traces of this fluid when supplied. (If you have ordered the pump for use with another fluid, the pump will be tested with the appropriate fluid.) You must refill the pump with the same type of fluid.

If you want to use a different fluid, you must clean the pump thoroughly before you fill it with the different fluid.

Refer to [Figure 1](#). There are two methods of filling the pump:

Method 1:

1. Ensure that the fluid drain plug (29) is securely tightened.
2. Pour the required amount of fluid (see [Section 2.4](#)) into a clean container.
3. Loosen the $\frac{1}{2}$ inch union nut and remove the dipstick (21) and the 'O' ring seal.
4. Pour the fluid through a funnel and into the pump through the dipstick port, to fill the pump with fluid.
5. Check the level with the dipstick. Add more fluid or drain fluid from the pump (refer to [Section 5.5](#)) as necessary.
6. When the fluid level is correct (indicated when the fluid level is shown on the upper mark on the dipstick):
 - Refit the dipstick (21) and the 'O' ring seal.
 - Tighten the $\frac{1}{2}$ inch union nut.

Method 2:

1. Ensure that the fluid drain plug (29) is securely tightened.
2. Pour the required amount of fluid (see [Section 2.4](#)) into a clean container.
3. Undo and remove the four screws which secure the cleaning port access lid (11), then remove the lid from the boiler covers.
4. Undo and remove the M10 nuts which secure the cleaning port cover (10), then remove the cover and gasket from the boiler. Dispose of the gasket: refer to [Section 6.2](#).
5. Pour the fluid directly into the boiler, through the cleaning port.
6. Check the level on the dipstick (21): if you use a torch, you should be able to see the level marks on the dipstick without having to remove it from the pump.
7. Add more fluid or drain fluid from the pump (refer to [Section 5.5](#)) as necessary.
8. When the fluid level is correct:
 - Refit the cleaning port cover (10) and a new gasket (available as a spare: see [Section 7.3](#)) to the boiler
 - Fit the M10 nuts to secure the cleaning port cover in place: tighten the nuts to a torque of 26 Nm.
 - Refit the cleaning port access lid (11) to the boiler covers and secure with the four screws.

Table 10 - Vapour pump fluid thermal breakdown

| Vapour pump fluid | Edwards product (other fluid type) | Auto-ignition temp. °C | Breakdown temp. °C | Thermal breakdown products | Type of danger | Possible injury |
|---|------------------------------------|------------------------|--------------------|--|---|--|
| Silicone fluids (methyl phenyl siloxanes) | DC702, DC704EU, DC705 | ≈ 500 | 400 | Decomposed hydrocarbons and silicon based species | Negligible | Negligible |
| Alkyl naphthalene fluid | Edwards L9 | 370 | ≈ 300 | Naphthalene and decomposed hydrocarbons | Naphthalene is poisonous in large quantities by ingestion and skin contact | Minor (first aid may be required) |
| Polyphenyl ether (5-Ring) | Santovac 5 | 590 | ≈ 480 (in helium) | Phenol, benzene and phenolic materials | Phenolic materials are poisonous and caustic by ingestion and skin contact | Major (a lost time accident can occur) |
| Paraffinic fluids & ester fluids | Apiezon A, B, C, AP201 and AP301 | ≥ 305 | < 300 (in air) | Decomposed hydrocarbons | Fire (Note: AP201 has a low auto-ignition temperature) | Major (a lost time accident can occur) |
| Perfluoro-polyether | None (Fomblin 18/8) | None | > 260 | Decomposed fluorocarbons including hydrofluoric acid | Highly aggressive materials. Poisonous and caustic by inhalation and skin contact | Potentially fatal |

3.12.3 Filling procedure for adjustment of the fluid low level switch



WARNING

Do not use this procedure to adjust the fluid low level switch when the pump is hot or under vacuum. If you do, hot fluid may be ejected from the pump.

Use the following procedure to fill the pump and to adjust the optional fluid low level switch. Where necessary, refer to the manufacturer's instructions for the level switch (refer to the list of Supplementary Publications at the end of the contents list).

Note that you will need the following tools to adjust the level switch:

- Small flat-head screwdriver.
 - 5 mm hexagonal key.
 - A power supply (for example 24 V d.c.).
 - A multimeter (or similar instrument) to measure electrical continuity.
1. Refer to [Figure 1](#). Fill the pump with fluid to the minimum mark on the dipstick (21): use the procedure given in [Section 3.12.2](#).
 2. If necessary, use the hexagonal key to loosen the level switch probe mounting sleeve.
 3. Connect your power supply to the level switch relay module, and connect your multimeter (or similar instrument) to the level switch outputs: refer to the manufacturer's instructions supplied.
 4. Adjust the height of the level switch probe in the mounting sleeve, so that the end of the level switch probe is in the pump fluid in the boiler, and so that there is continuity across the probe outputs.
 5. Slowly adjust (raise) the height of the level switch probe in the sleeve until there is no continuity across the probe outputs (that is, the level switch will operate just above the minimum fluid level).
 6. Ensure that the notch indicator in the hexagonal probe nut faces upwards, then use the hexagonal key to tighten the probe mounting sleeve.
 7. Disconnect the power supply and multimeter (or similar instrument) from the level switch.
 8. Leave the level switch installation for 20 minutes or more. (During this time, you can complete the filling procedure: see next step.)
 9. Complete the filling procedure, to fully fill the pump with fluid: refer to [Section 3.12.2](#).
 10. Use the hexagonal key to tighten the probe mounting sleeve again, to ensure leak tightness.

3.13 Connect the optional fluid low level switch (if fitted)

Note: Only connect the level switch once you have correctly adjusted it: refer to [Section 3.12.3](#).

Connect the fluid low level switch outputs to your control or indicator equipment as described in the manufacturer's instructions supplied.

Refer to [Section 2.6](#) for the output electrical characteristics.

This page has been intentionally left blank.

4 Operation

4.1 Introduction



WARNING

Do not pump gases which are flammable at pressures in the operating pressure range of the 18B4B pump. If you do, this may result in an explosion or fire. If in doubt about the compatibility of gases with the use of the 18B4B pump, contact Edwards for advice.



WARNING

Do not operate the pump when the cooling-water flow through the cooling-coils is restricted. If you do, water in the cooling-coils may boil, the cooling-coils may fracture, and hot water and steam which escapes from the cooling-coils may injure people.



WARNING

Do not touch any part of the pump when it is switched on. Avoid contact between the pump and combustible materials, plastic materials and electrical cables. Surfaces of the pump are very hot and can cause injury to people and damage to equipment.



WARNING

If the cooling-water supply fails, allow the pump to cool before you disconnect the cooling-water supply and return pipelines from the pump. If you do not, steam or water may be ejected from the cooling coil when you disconnect the pipelines and you may be injured.

4.2 Check the insulation resistance of the heaters

If the heaters in the pump have absorbed moisture while the pump was switched off, the insulation resistance of the heaters may be too low. Use the following procedure to measure the insulation resistance of the heaters before you switch the pump on.

If you have an RCCB in your electrical supply circuit, you do not need to measure the insulation resistance of the heaters, because the RCCB will operate to disconnect the electrical supply from the pump if the insulation resistance is too low. If your RCCB has operated, use this procedure to check the insulation resistance of the heaters before you reset the RCCB.

1. Measure the insulation resistance (at 500 V d.c.) between any of the heater terminals (see [Figure 5](#)) and earth (ground). Then:
 - Multiply the measured resistance by the number of heaters in the pump, to calculate the insulation resistance per heater.
 - If the insulation resistance per heater is greater than 1 M Ω , you can switch on the pump.
 - If the insulation resistance per heater is less than 1 M Ω , continue at Step 2.
2. Remove the heaters from the pump (refer to [Section 5.8](#)). Bake the heaters in an oven at a temperature of 120 °C for 12 hours or more.

3. Remove the heaters from the oven. Measure the insulation resistance of each heater:
 - If a heater has an insulation resistance greater than 1 M Ω , you can refit the heater to the pump.
 - If a heater has an insulation resistance less than 1 M Ω , repeat Steps 2 and 3 of this procedure. If the insulation resistance of a heater is less than 1 M Ω after the heater has been baked for 24 hours, then the heater is faulty and you must replace it with a new heater.

Note: *The following sections apply to 18B4B pumps which are operated in conjunction with a fully valved pumping system, as shown in Figure 12.*

Details of the baffle and isolation valves recommended for use in these pumping systems are given in Section 7.4.

4.3 Start-up



WARNING

Unless you have an RCCB fitted, do not switch on the electrical supply to the pump if the insulation resistance of the pump heaters is less than 1 M Ω (see Section 4.2). If you do, there is a risk of injury or death by electric shock as a result of the earth (ground) leakage current.

Note: *If you do not have an RCCB in your electrical supply circuit, you must check the insulation resistance of the heaters as described in Section 4.2 before you switch on the 18B4B pump.*

1. Close the high-vacuum baffle valve and air admittance valve(s). Close any other openings to atmospheric pressure.
2. Open the backing pump isolation valves.
3. Switch on the cooling-water supply to the 18B4B pump. Check that the cooling-water flow is correct.
4. Switch on the backing pump.
5. When the backing pressure reaches 1.3 mbar (1.3×10^2 Pa) or lower, switch on the electrical supply to the 18B4B pump, then leave the 18B4B pump to warm up for 40 to 60 minutes.
6. Close the backing valve, then open the roughing valve.
7. When a system pressure of 0.2 mbar (2×10^1 Pa) or lower is reached, close the roughing valve and open the backing valve.
8. Open the high-vacuum baffle valve.

4.4 Rough pumping

If you have a large vacuum system and rough pumping takes a considerable time, you may need to install a small holding pump and valve, in order to back the 18B4B pump during roughing.

If you have installed a holding pump (as shown in Figure 12), use the following procedure:

1. Start up the system as described in Steps 1 to 5 of Section 4.3.
2. Switch on the holding pump and open the holding valve.
3. Close the backing valve and open the roughing valve.
4. Pump down the system to 0.2 mbar (2×10^1 Pa) or lower, then close the roughing valve and open the backing valve.
5. Open the high-vacuum baffle valve.
6. Close the holding valve and switch off the holding pump.

4.5 Adjust the boiler protection thermal snap-switch (if necessary)

Note: You must adjust the thermal snap-switch when the 18B4B pump is fully charged with fluid, is at operating temperature and is under vacuum. If you do not, the snap-switch may not operate at the correct temperature, and the pump may overheat.

As supplied, the boiler protection thermal snap-switch is preset to operate to shut down the pump when the boiler temperature reaches 250 °C.

If you need to adjust the snap-switch to operate at a different temperature, use the following procedure:

1. Refer to [Figure 11](#). Loosen the locking screw (3) on the snap-switch.
2. Slowly turn the temperature set screw (2) clockwise until the snap-switch just trips open; the pump will then automatically shut down.
3. Turn the set screw anticlockwise again by $\frac{3}{4}$ of a complete turn (270°); one complete anticlockwise revolution of the screw (in the direction of the arrow, 4) is equivalent to an increase in the operating temperature of approximately 40 °C.
4. When you have set the snap-switch, tighten the locking screw (3).
5. Restart the pump.

Figure 11 - Adjust the boiler protection thermal snap-switch

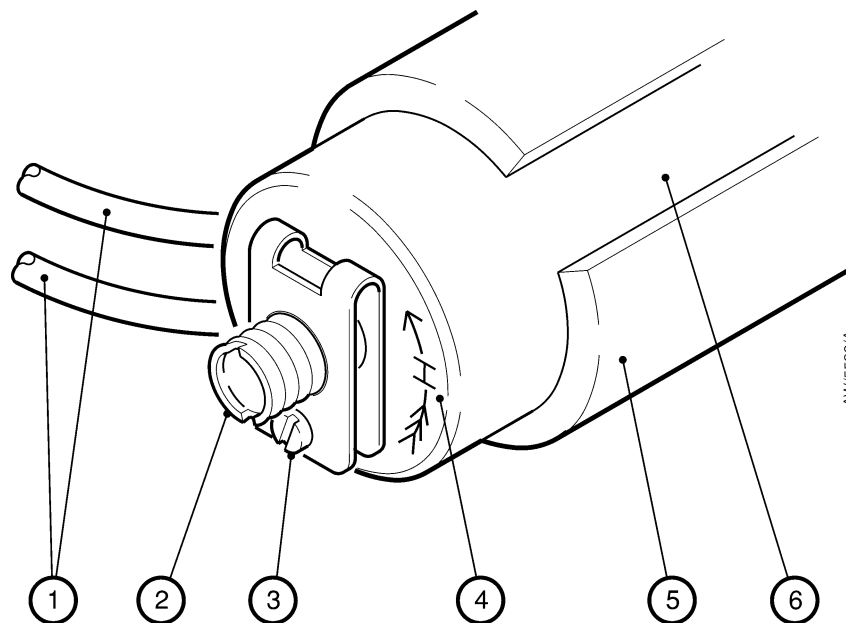

1. Electrical wires
2. Temperature set-screw
3. Locking screw
4. Arrow
5. Mounting sleeve
6. Snap-switch body

4.6 Re-admission of air to your vacuum system



WARNING

Do not admit air into the pump through the dipstick assembly or any other port until the pump has cooled to ambient temperature. If you do, the pump fluid may ignite, or expansion of admitted air can cause hot fluid to be ejected from the pump.

1. Close the baffle valve and ensure that the backing valve is open.
2. Open the chamber air admittance valve.

4.7 Re-evacuation of your vacuum system

1. Close the chamber air admittance valve and any other openings to atmosphere.
2. Close the backing valve, and then open the roughing valve.
3. When a system pressure of 1 or 2 mbar (1×10^2 or 2×10^2 Pa) or lower is reached, open the backing valve.
4. Slowly open the baffle valve; if you open the baffle valve too quickly, you can stall the vapour booster pump.

4.8 Shut-down



WARNING

Do not admit air into the pump through the dipstick assembly or any other port until the pump has cooled to ambient temperature. If you do, the pump fluid may ignite, or expansion of admitted air can cause hot fluid to be ejected from the pump.

The following method of shut-down of the system ensures that the 18B4B pump is left evacuated and so prevents the absorption of air by the pump fluid.

When you subsequently start up, evacuate the system through the roughing pipeline to a pressure of 1 or 2 mbar (1×10^2 or 2×10^2 Pa) or lower before you switch on the 18B4B pump.

1. Close the baffle valve.
2. Switch off the electrical supply to the 18B4B pump heater and allow the pump to cool for at least 2 hours. If you do not allow the pump to cool before you admit air, on re-evacuation the pump fluid will superheat and evolve vapour, which will pass into the backing pipeline.
3. Close the backing valve.
4. Open the backing pump air admittance valve, then switch off the backing pump. Do not switch off the backing pump unless air is admitted to the vapour booster pump, or backing pump oil may be drawn into the backing pipeline.
5. Leave the 18B4B pump to allow the pump boiler to cool to 100 °C or below, then turn off the cooling-water supply to the pump.

Figure 12 - Typical pumping system

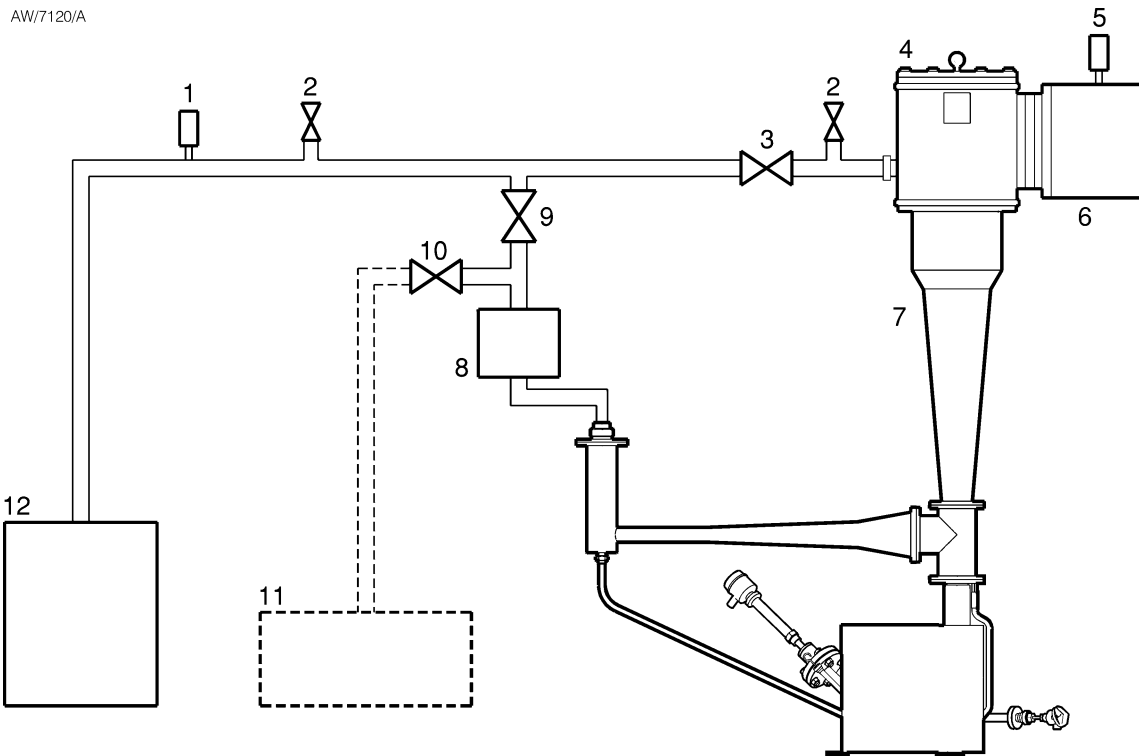

- | | |
|------------------------------|-------------------|
| 1. Backing gauge head | 7. 18B4B pump |
| 2. Pump air-admittance valve | 8. Moisture trap |
| 3. Roughing valve | 9. Backing valve |
| 4. High-vacuum baffle-valve | 10. Holding valve |
| 5. High-vacuum gauge head | 11. Holding pump |
| 6. Work chamber | 12. Backing pump |

This page has been intentionally left blank.

5 Maintenance

5.1 Safety



WARNING

Obey the safety instructions given below and take note of appropriate precautions. If you do not you can cause injury to people and damage to equipment.

- A suitably trained and supervised technician must maintain the 18B4B pump.
- Ensure that the maintenance technician is familiar with the safety procedures which relate to the pump fluid and to the products pumped. Wear the appropriate safety-clothing when you come into contact with contaminated components. Dismantle and clean contaminated components inside a fume-cupboard.
- Isolate the pump from the electrical supply and your vacuum system before you start maintenance work.
- Allow the pump to cool fully before you touch any part of the pump (including the dipstick and the drain plug) or attempt to move it. Open the pump to atmospheric pressure when it is cool.
- Always allow the pump to cool for at least 2 hours before you turn off the cooling-water supply.
- Do not remove the dipstick or open the drain-plug or any other port to vent the pump while the pump is operating or under vacuum.
- Use suitable lifting equipment when you move the pump. (Refer to [Section 3.3](#) for the method of lifting and to [Section 2.3](#) for the mass of the pump.)
- Do not touch or inhale the thermal breakdown products of fluorinated materials which may be present if the pump has been overheated to 315 °C and above. These breakdown products are very dangerous. Fluorinated materials in the pump may include seals and 'O' rings. The pump may have overheated if it was misused, if it malfunctioned or if it was in a fire. Edwards Material Safety Data Sheets for fluorinated materials used in the pump are available on request; contact your supplier or Edwards.
- Do not touch or inhale the thermal breakdown products of the pump fluid if the pump has been overheated.
- Do not use abrasive or reactive chemical substances to clean the pump.
- Do not use solvents to clean 'O' rings.
- If you need to work under the pump, wear suitable protective clothing, eye protection and breathing apparatus.

5.2 Tools and equipment required

You will need the following tools and equipment to carry out the maintenance operations described in the following sections:

- Lifting equipment (hoist or crane)
- Set of metric spanners
- Set of metric hexagonal keys
- Adjustable wrench
- Paraffin based cleaning solution
- Abrasive pads
- Lint free wipes

- Length of flexible rod
- Torque wrench (20 to 50 N m; 15 to 40 lbf ft) with 17 mm socket

5.3 Maintenance plan

The plan shown in [Table 11](#) lists the maintenance operations necessary to maintain the pump in normal use. Instructions for each operation are given in the section shown.

Table 11 - Maintenance plan

| Operation | Frequency | Refer to Section |
|---|--------------------|------------------|
| Check the pump fluid-level | Weekly | 5.4 |
| Inspect the pump fluid and drain if necessary | As required | 5.5 |
| Clean and inspect the pump | Yearly/As required | 5.6 |
| Clean the radiation shield | As required | 5.7 |
| Replace a pump heater | As required | 5.8 |
| Check the heater clamp plate and retaining nuts | Every 500 hours * | 5.9 |
| Clean the cooling-coil | As required | 5.10 |

* You must also check the heater clamp plate and retaining nuts 200 hours after you have replaced a heater.

More frequent maintenance may be required if the pump has been used to process corrosive or abrasive gases and vapours. If necessary, adjust the maintenance plan according to your experience.

5.4 Check the pump fluid-level

If the pump boiler operates at a higher than normal temperature, check the level of fluid in the pump boiler as described below.

1. Allow the pump to cool and open it to atmospheric pressure.
2. Refer to [Figure 1](#). Loosen the $\frac{1}{2}$ inch union nut and remove the dipstick (21) and 'O' ring seal and check the fluid-level. The fluid-level should be visible on the dipstick, between the two (minimum and maximum) level marks.
3. If the fluid-level is low, add more fluid as detailed in [Section 3.11](#).
4. Allow the fluid to drain into the boiler and check the level again. If the level is too high, drain the excess fluid (see [Section 5.5](#)).
5. Inspect the dipstick 'O' ring. Replace the 'O' ring if it is damaged or if thermal set has taken place.
6. Refit the dipstick and tighten the $\frac{1}{2}$ inch union nut.

5.5 Inspect the pump fluid (and drain if necessary)

Notes: 1. If required, you can remove the cleaning port cover (refer to [Section 5.6.5](#)) and inspect the pump fluid without having to drain the pump. If you do this, you must replace the gasket when you refit the cover.

2. If your pump has a Pt100 temperature probe fitted, the probe is integral to the fluid drain plug and you must remove the probe in order to drain the fluid from the pump.

If the pump fails to give satisfactory performance on a leak tight system, inspect the condition of the pump fluid as described below.

1. Allow the pump to cool and open it to atmospheric pressure.

2. If the pump is cold, switch on the pump heaters for a maximum of two minutes to warm the pump fluid to aid draining. Do not vaporise the pump fluid.
3. Refer to [Figure 1](#). Place a suitable container (with a capacity of at least 10 l) under the fluid drain connection (29).
4. Loosen the 1 inch union nut on the fluid drain connection (see Note 2 above) and allow the fluid to drain from the pump.
5. Disconnect the pump from the electrical supplies.
6. Disconnect the inlet (1) and outlet (16) from your vacuum system.
7. Visually check the interior of the pump:
 - If it is badly discoloured or coated with charred fluid, the pump fluid has deteriorated and must be changed; clean the pump as described in [Section 5.6](#).
 - If the fluid is in a satisfactory condition, refill the pump as described in [Section 3.11](#) and reconnect it to your vacuum system and to the electrical supply.

5.6 Clean and inspect the pump

5.6.1 Introduction



WARNING

Remove all traces of the cleaning solution before you operate the pump. If you do not, there may be a risk of fire or explosion.

When you clean the pump, choose the cleaning solution to suit the type of pump fluid that has been used.

Note that the jet assembly can be vapour de-greased if required.

5.6.2 Dismantle the pump



WARNING

Use suitable lifting equipment to move the pump or heavy components/assemblies of the pump. If you do not, you can injure yourself or damage the pump. Refer to [Section 2.3](#) for the mass of the pump and parts/assemblies of the pump.

Notes: 1. If your pump has a Pt100 temperature probe fitted, the probe is integral to the fluid drain plug and you must remove the probe in order to drain the fluid from the pump.

2. If there is a significant amount of sediment in the boiler, the drain port may become blocked when you drain the fluid. If this happens, push a suitable length of rod into the drain port to clear the blockage.

1. Switch off the pump and isolate it from the electrical supply
2. Allow the pump to cool and open it to atmospheric pressure.
3. Disconnect the cooling-water supply and return pipelines from the cooling-water inlet and outlet (4, 15).
4. Refer to [Figure 1](#). Loosen the $\frac{1}{2}$ inch union nut and remove the dipstick (21).
5. Place a suitable container (with a capacity of at least 10 l) under the fluid drain connection (29).
6. Loosen the 1 inch union nut on the fluid drain connection (see Note 1 above), and allow the pump fluid to drain into the container.

7. If the pump is fitted to the vacuum system:
 - Use a wide-track pallet truck or fork-lift to raise the pallet (on which the pump was supplied) under the pump, so that the fixing holes on the pump (Figure 3, items 13) align with the fixing holes in the pallet.
 - Fit the nuts, bolts and washers (retained when you installed the pump) through the fixing holes to secure the pump to the pallet.
 - Disconnect the pump inlet (1) and outlet (16) from your vacuum system.
 - Slowly and carefully lower the pump and (if required) move it to the location where you will carry out maintenance.
 - Continue at Step 9.
8. If the pump is free-standing:
 - Disconnect the pump inlet (1) and outlet (16) from your vacuum system, then move the inlet and outlet pipelines away from the pump.
 - Alternatively: If necessary, disconnect the electrical cables from the pump, then use suitable lifting equipment to move the pump away from the pipelines: use the method described in Section 3.3.3.
9. Disconnect the cooling couplings (36, 40) that link the top cone and the side cone cooling-coils to the cooling coils on the 'T' piece.
10. Undo the four M8 fixing bolts which secure the guard ring (2), and remove the guard ring.
11. Unscrew and remove the top jet cap (47), then remove the top and second stage vapour tubes (5 and 6).
12. Unscrew and remove the tie-rod (35) from the securing plate in the boiler.
13. Attach suitable slings to the pump under the inlet flange, then attach suitable lifting equipment (such as an overhead crane or hoist) to the slings, to support the top cone assembly (45). (Refer to Section 2.3 for the mass of the top cone assembly.)
14. Remove the six M8 screws that secure the top cone (45) to the pump body, then use the lifting equipment to remove the top cone. Carefully place the top cone on a clean work surface.
15. Remove the six M5 cap-head screws that secure the lower vapour tube (42) to the boiler assembly, then remove the vapour tube and the jet gasket (39).
16. Undo the M6 fixing screw, and lift the baffle assembly (18) out of the backing condenser.
17. Undo the 1 inch BSP union nut on the condenser fluid return pipe (20).
18. Attach two slings to the side cone assembly (14), then attach the slings to suitable lifting equipment to support the cone assembly. (Refer to Section 2.3 for the mass of the side cone assembly.)
19. Undo and remove the six M8 nuts which secure the side cone assembly to the boiler (33).
20. Remove the side cone assembly (14), and carefully place the assembly on a clean work surface.
21. Unscrew and remove the ejector nozzle (8).
22. Undo the six M8 screws which secure the 'T' piece (38) to the boiler (33), and remove the 'T' piece.

5.6.3 Clean the main pump components

Use the following procedure to clean the top cone assembly (45), 'T' piece (38) and guard ring (2):

1. Refer to Figure 1. Inspect the interior of the components. If there are solid deposits of pump fluid, use an ultrasonic cleaning bath to remove the deposits.
2. Use a cleaning solution (suitable for the pump fluid used) to clean the components.

3. Wash the components with acetone to remove all traces of the cleaning solution.
4. Bake the components to 77 °C to remove the acetone. Alternatively, pass warm air over the components.
5. Inspect all sealing faces and check that they are free from scratches. Refinish sealing surfaces that are scratched.

5.6.4 Clean the interior components

Refer to [Figure 1](#) and use the following procedure:

1. Clean the interior jet stages components (5, 6, 35, 42 to 45, 47) in a degreasing tank. Alternatively, wipe down the components with a suitable paraffin based cleaning solution:
 - Pay particular attention to the jet formation areas (that is, items 43, 44 and 47, and the tops of items 5, 6 and 42).
 - If there are solid deposits on the components, use an abrasive pad to remove the deposits.
2. Clean the backing baffle assembly (18): use the methods described in Step 1 above.

5.6.5 Clean the boiler and fluid return pipes

Refer to [Figure 1](#) and use the following procedure:

1. Undo and remove the four screws which secure the cleaning port access lid (11) to the boiler covers, and remove the lid.
2. Undo and remove the M10 nuts which secure the cleaning port cover (10) to the boiler, then remove the cover.
3. Remove the cleaning port gasket, then dispose of it: refer to [Section 6.2](#).
4. Place a suitable container under the fluid drain connection (29), to collect any cleaning solution.
5. Support the boiler assembly (33) and tilt it slightly towards the fluid drain connection. (Refer to [Section 2.3](#) for the mass of the boiler assembly.)
6. Pour a suitable paraffin based cleaning solution into the boiler (33) (alternatively spray the solution under pressure into the boiler), directly through the cleaning port, through the 'T' piece (38) and through the jet stack fluid return pipe (34).
7. Check that the cleaning solution drains into the boiler without obstruction.
8. Use a suitable flexible rod to clean any deposits from the jet stack fluid return pipe (34).
9. Clean the condenser fluid return pipe (20): use the method in Steps 4 to 6 above.
10. Inspect the side cone assembly (14): remove any deposits and flush out with cleaning solution if necessary.
11. Inspect the interior of the boiler (33). If there are still hard deposits on the body of the boiler, do not try to remove these mechanically; instead, use an ultrasonic cleaning bath to clean the boiler.

5.6.6 Reassemble the pump

Note: *You must position the guard ring correctly when you reassemble the pump. If you do not, the pump performance will be reduced. The method described below requires enough headroom (and a suitable crane or hoist) to enable the top cone to be lifted over the jet stack assembly. If this is not possible, you can carry out Step 10 before Step 9, however it will be more difficult to properly align the jet stack.*

Refer to [Figure 1](#) and use the procedure below to reassemble the pump.

We recommend that you replace all of the 'O' ring and gasket seals when you reassemble the pump. You must replace the cleaning port gasket. Refer to [Section 7.3](#) for the Item Numbers of spare seals.

1. Use the M8 screws to secure the 'T' piece (38) and 'O' ring (37) on the top flange of the boiler (33). Tighten the screws by hand only. Do not fully tighten the screws.
2. Lightly coat the threads of the ejector nozzle (8) with anti-seize compound, then screw the nozzle into the boiler tube.
3. Ensure that the 'T' piece (38) is positioned so that the ejector nozzle (8) is concentric with the side (horizontal) flange of the 'T' piece, then fully tighten the M8 screws on the lower flange of the 'T' piece.
4. Position the 'O' ring on the 'T' piece side flange.
5. Attach two slings and suitable lifting equipment to the side cone assembly (14) to support it, then fit the side cone to the 'T' piece (38) and loosely fit the retaining nuts.
6. Reconnect the condenser fluid return pipe (20) and 'O' ring to the condenser (17), then fully tighten the retaining nuts on the side cone assembly (14).
7. Refit the baffle assembly (18) in the backing condenser (17) and secure with the M6 screw.
8. Fit a new jet gasket (39), then attach the lower vapour tube (42) to the boiler tube and secure the mounting flange with the M5 retaining screws.
9. Refit the tie-rod (35), assemble the second stage vapour tube (6) and the top vapour tube (5), then screw the top jet cap (47) onto the tie-rod.
10. Position the 'O' ring on the top flange of the 'T' piece (38), then use slings and an overhead crane or hoist to carefully fit the top cone assembly (45) to the 'T' piece, and secure it with the retaining screws and nuts.
11. Place the guard ring (2) in position and use the retaining screws to secure it to the lugs on the interior of the top cone assembly.
12. Ensure that the gap setting (48) between the lower edge of the guard ring and the lower edge of the top jet cap (34) is correctly set:
 - Set the gap to 1.6 mm for use with AP201 fluid.
 - If you use the pump with another fluid, contact your supplier or Edwards for advice.

Loosen and re-tighten the retaining screws as necessary to obtain the correct gap setting.
13. Refit the cooling couplings (36, 40) that connect the main cone and ejector cone cooling-coils to the cooling-coils on the 'T' piece.
14. Fit a new gasket and refit the cleaning port cover (10) to the boiler (33).
15. Fit the M10 nuts to secure the cover in place: tighten the nuts to a torque of 26 Nm.
16. Refit the cleaning port access lid (11) to the boiler covers. Fit and tighten the four screws to secure the lid in place.

5.6.7 Prepare the pump for operation



WARNING

Use suitable lifting equipment to move the pump. If you do not, you can injure yourself or damage the pump. Refer to [Section 2.3](#) for the mass of the pump.

1. If your pump was installed on the vacuum system:
 - Use suitable lifting equipment and re-install it as described in [Section 3.3.2](#).
 - Continue at Step 3.

2. If your pump is free-standing:
 - If necessary (that is, if you have moved the pump away from your inlet and outlet pipelines), use suitable lifting equipment to move the pump back into its operating position: use the method described in [Section 3.3.3](#).
 - Refer to [Figure 1](#). Fit the 'O' ring (3) to the inlet (1).
 - Reconnect the inlet (1) and outlet (16) to your vacuum system.
3. Reconnect any electrical cables which you may have disconnected.
4. Reconnect the cooling-water supply and return pipelines to the cooling-water inlet (4) and outlet (15).
5. Fill the pump with fluid: refer to [Section 3.11](#).

5.7 Clean the radiation shield

Keep the radiation shield ([Figure 1](#), item 22) which surrounds the pump boiler clean to maintain thermal efficiency.

To clean the external surface of the radiation shield:

1. Switch off the pump and isolate it from the electrical supply.
2. Leave the pump and allow it to cool for at least 60 minutes.
3. Use a soft cloth (and a suitable cleaning solution if necessary) to wipe clean the radiation shield.

If you need to clean the internal surface of the radiation shield

- Remove the radiation shield from the pump.
- Clean the radiation shield: use the method described above.
- Refit the radiation shield to the pump.

5.8 Replace a pump heater

Note: Heater spares packs (see [Section 7.3](#)) contain new heaters, crimps, terminals, wires and ceramic insulation beads.

5.8.1 Prepare the pump



WARNING

Use suitable lifting equipment to move the pump. Refer to [Section 2.3](#) for the mass of the pump.

1. Switch off the pump and isolate it from the electrical supply.
2. Allow the pump to cool and open it to atmospheric pressure.
3. Refer to [Figure 13](#). Remove the screws which secure the cover to the terminal box (1), then remove the cover.
4. Disconnect the electrical supply wires from the terminal block (17).
5. Refer to [Figure 1](#). Switch off your cooling-water supply, then disconnect your cooling-water supply and return pipelines from the cooling-water inlet (4) and outlet (15) on the pump.
6. If necessary, disconnect the thermal snap-switch wires from the cooling-fail thermal snap-switch ([Figure 1](#), item 9).

7. If necessary, remove the pump from the vacuum system and move it to the location where you will replace the heater: use the method in Steps 7 and 8 of [Section 5.6.2](#).

5.8.2 Identify and remove the defective heater

1. Refer to [Figure 13](#). Place a suitable support under the heaters and terminal box assembly: the support must be capable of holding the mass of the assembly (see [Section 2.3](#)).
2. Disconnect the earth (ground) strap (19) from the stud on the side of the pump.
3. Loosen the nuts (18) which secure the terminal box assembly.
4. Undo and remove the three nuts (13) and washers which secure the heater assembly, then lower the heaters (9), heater sleeves (7), washers (12), perforated plate (11) and terminal box (1) assembly from the pump.
5. Remove any hard scale or deposits from the base of the pump.
6. Carefully remove the cover from the terminal block (17): ensure that you do not damage the threads in the ceramic block. (Note that you may have to use a heat-gun to release the sealing compound used during pump assembly.)
7. Check the electrical continuity of each heater (9) to identify the defective heater.
8. Disconnect the defective heater from the terminal block (17).
9. Remove the half nut and washer (14) from the defective heater.
10. Carefully remove the heater sleeve (7) and the clamp and spacer assembly (10).
11. Carefully remove the defective heater (9) and the backing plate (6): pull the heater wires through the holes in the radiation shield (5).
12. Remove the defective heater (9) from the backing plate (6).

Figure 13 - Replace a heater

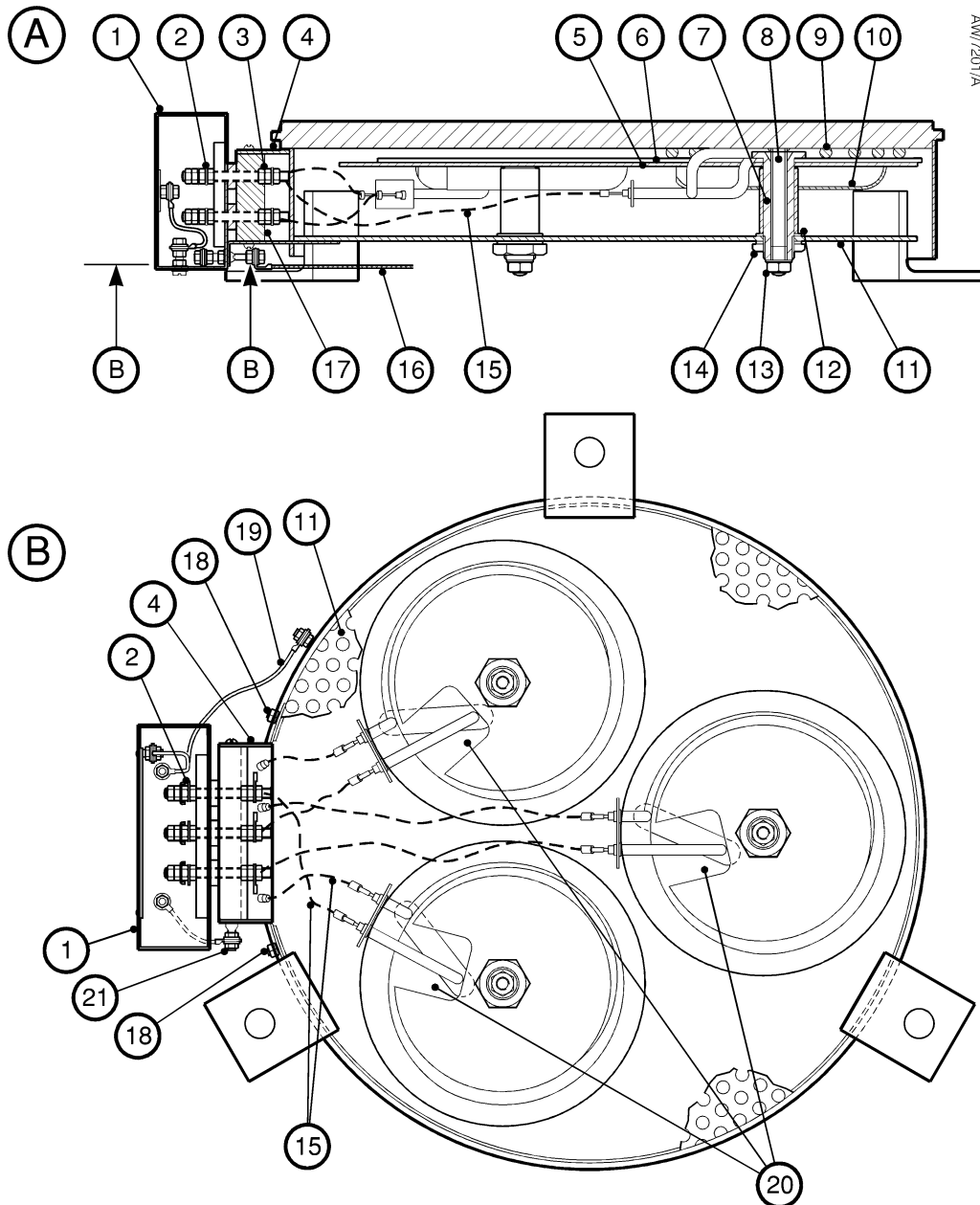

AM7201/A

- A. Side view
B. Top view

- | | | |
|-------------------------|--------------------------------------|------------------------------------|
| 1. Terminal box | 9. Heater | 15. Nickel wire with ceramic beads |
| 2. Busbar | 10. Heater clamp and spacer assembly | 16. Earth (ground) wire |
| 3. Terminal nut | 11. Perforated plate | 17. Terminal block |
| 4. Terminal block cover | 12. Heater washer | 18. Securing nuts |
| 5. Radiation shield | 13. Nut and washer | 19. Earth (ground) strap |
| 6. Heater backing plate | 14. Half nut and washer | 20. Cut-outs (in clamp plates) |
| 7. Heater sleeve | | 21. Earth (ground) stud |
| 8. Heater mounting stud | | |

5.8.3 Assemble and fit the new heater

1. Refer to [Figure 13](#). Crimp the nickel wires (14) to the heater: use the uninsulated butt-splices supplied.
2. Cut the nickel wires (14) to the required lengths: use the defective heater (removed in [Section 5.8.2](#)) as a guide to the required lengths.
3. Fit the ceramic beads to the nickel wires (14): use a sufficient number of beads to fully cover the wires.
4. Crimp the uninsulated terminals to the nickel wires (14), so that the ceramic beads are tightly secured.
5. Bend the wires and beads to shape: use the defective heater (removed in [Section 5.8.2](#)) as a guide to the required shape.
6. Pass the heater wires through the backing plate (6) and then through the radiation shield (5).
7. Lightly coat the terminals with a suitable high-temperature anti-seize compound, then connect the terminals to the terminal nuts (3).
8. Refit the heater clamp and spacer assembly (10): ensure that the cut-out (20) in the clamp plate is correctly aligned as shown in [Figure 13](#).
9. Lightly coat the threaded part of the heater sleeve (7) with a suitable high-temperature anti-seize compound.
10. Fit the heater sleeve (7) and the half nut and washers (12, 14), and tighten to a torque of 20 Nm.
11. Check the electrical continuity of the new heater (8) to ensure that it has been installed correctly.
12. Check the electrical continuity of the other two heaters, to ensure that they have not been disturbed or damaged.

5.8.4 Reassemble the pump



WARNING

Use suitable lifting equipment to move the pump. Refer to [Section 2.3](#) for the mass of the pump.

1. Refer to [Figure 13](#). Refit the terminal block cover (4): ensure that you do not damage the threads in the ceramic block. If required, use a suitable thread sealant (such as Loctite 496) to secure the screws.
2. Lightly coat the heater mounting studs (8) with a suitable high-temperature anti-seize compound.
3. Refit the heater assembly and secure with the retaining nuts and washers (13): tighten to a torque of 44 Nm.
4. Tighten the nuts (18) which secure the terminal box (1).
5. Reconnect the earth (ground) strap (19) to the stud on the side of the pump.
6. If necessary, reconnect the pump to your vacuum system: use the method in Steps 1 and 2 of [Section 5.6.7](#).
7. Refer to [Figure 1](#). If necessary, reconnect the thermal snap-switch wires to the cooling-fail thermal snap-switch (9).
8. Reconnect your cooling-water supply and return pipelines to the cooling-water inlet (4) and outlet (15) on the pump.
9. Check the insulation resistance of the pump, to ensure that there is no abnormal earth (ground) leakage. If there is abnormal earth (ground) leakage, identify and rectify the problem.
10. Refer to [Figure 13](#). Reconnect the electrical supply wires to the terminal block (16).

11. Inspect the condition of the pump fluid and drain if necessary: refer to [Section 5.5](#).

If the pump fluid condition is satisfactory, check the pump fluid-level: refer to [Section 5.4](#).

You can now operate the pump again, as described in [Section 4](#).

5.9 Check the heater clamp plate and retaining nuts

You must regularly check the heater clamp plate and retaining nuts, to ensure that the heaters make good contact with the pump base. If a heater does not make good contact, thermal transfer will be inefficient, and the heater may overheat.

Refer to [Figure 13](#) and use the following procedure to check the heater clamp plate and retaining nuts:

1. Check that the heater clamp and spacer assembly (10) is tight. Tighten if necessary.
2. Check that each of the three heater retaining nuts (13) is tight. If necessary, tighten the nut to a torque of 44 N m.

5.10 Clean the cooling-coil

You must clean the cooling-coil at least once a year, and more regularly if the water supply has a high calcium content.

To clean the cooling-coil:

1. Flush the cooling-coil with a suitable descaling agent. For example, a 15% hydrochloric acid solution can be used for decalcification, followed by a 5% sodium carbonate solution for neutralization.
2. Flush the cooling-coil through with clean water, to ensure that no descaling agent (or neutralizer) remains in the cooling-coil.

5.11 Fault finding

A list of fault conditions and their possible causes is provided in [Table 12](#) to assist you in basic fault-finding.

If problems persist, contact your supplier or your nearest Edwards Service Centre.

Table 12 - Fault finding

| Fault symptom | Possible causes |
|--------------------------|--|
| The pump will not start. | The electrical supply connections are disconnected. The electrical supply thermal overload has tripped. |
| The pump shuts down. | The electrical supply connections have become disconnected. The electrical supply thermal overload has tripped. One of the thermal snap-switches has operated. |

Table 12 - Fault finding (continued)

| Fault symptom | Possible causes |
|---|---|
| The pump fails to reach ultimate vacuum, or low-pressure pumping speed is poor. | There is a leak in your vacuum system. There is a leak in the pump. The pump fluid is contaminated. Your vacuum system is contaminated. A heater has failed. The guard ring is incorrectly fitted/adjusted. The pump has been filled with new pump fluid. The cooling-water temperature is too high. Your pressure gauge is incorrectly calibrated. |
| High-pressure pumping speeds are poor. | The backing pump is too small or is faulty. There is a leak in the backing pipeline. The fluid-level is incorrect. There is a restriction in the pump-outlet. The pump interior assembly is installed incorrectly. A pump heater has failed. The diameter of the backing pipeline is too small or the backing pipeline is too long. |
| Pumping is unstable. | The fluid return to the pump boiler is restricted. The pump fluid-level is low. |
| Pressure is unstable. | The pump fluid-level is incorrect. The guard ring is incorrectly fitted/adjusted. The cooling-water flow is restricted. The pump interior assembly is assembled incorrectly. The cooling-water temperature is too high. |
| Backstreaming is excessive. | The cooling-water temperature is too high. The cooling-water flow is restricted. |
| Pump fluid loss is excessive. | The guard ring is incorrectly fitted/adjusted. The cooling-water flow is restricted. The cooling-water temperature is too high. The pump is stalled due to a high gas load or high backing pipeline pressure. |

6 Storage and disposal

6.1 Storage

Use the procedure below to store the pump:

1. Shut down the pump as described in [Section 4.8](#).
2. Isolate the pump from the electrical supply.
3. Refer to [Figure 1](#). Disconnect the inlet (1) and outlet (16) from your vacuum system.
4. Drain the pump fluid as described in [Section 5.5](#).
5. Dismantle, clean and reassemble the pump as described in [Section 5.6](#). Do not refill the pump with fluid.
6. Place protective covers over the inlet (1) and outlet (16) and the cooling-water inlet (4) and outlet (15) connectors.
7. Store the pump in cool dry conditions until it is required for use.

When required, prepare and install the pump as described in [Section 3](#).

6.2 Disposal

Dispose of the pump, pump fluid and any components removed from the pump safely in accordance with all local and national safety and environmental requirements.

Take particular care with the following:

- Components which have come into contact with pump fluid.
- Fluoroelastomers which may have been subjected to temperatures above 315 °C (see [Section 5.1](#)).
- Breakdown products which may be present if the pump fluid has been subjected to temperatures above the fluid breakdown temperature.
- Components or used pump fluid which have been contaminated with dangerous process substances.

This page has been intentionally left blank.

7 Service, spares and accessories

7.1 Introduction

Edwards products, spares and accessories are available from Edwards companies in Belgium, Brazil, China, France, Germany, Israel, Italy, Japan, Korea, Singapore, United Kingdom, USA and a world-wide network of distributors. The majority of these employ service engineers who have undergone comprehensive Edwards training courses.

Order spare parts and accessories from your nearest Edwards company or distributor. When you order, please state for each part required:

- Model and Item Number of your equipment
- Serial number (if any)
- Item Number and description of the part

7.2 Service

Edwards products are supported by a world-wide network of Edwards Service Centres. Each Service Centre offers a wide range of options including: equipment decontamination; service exchange; repair; rebuild and testing to factory specifications. Equipment which has been serviced, repaired or rebuilt is returned with a full warranty.

Your local Service Centre can also provide Edwards engineers to support on-site maintenance, service or repair of your equipment.

For more information about service options, contact your nearest Service Centre or other Edwards company.

7.3 Spares

The spares for the 18B4B pumps are listed in [Table 14](#) (page 52).

7.4 Accessories

The accessories for the 18B4B pumps are listed in [Table 13](#).

Table 13 - 18B4B accessories

| Accessory | Item Number |
|---|-------------|
| P12R12A baffle and isolation valve (pneumatically operated) | B046-05-000 |
| Adaptor flange for baffle and isolation valve * | B046-05-078 |
| Cooling-fail thermal snap-switch | B023-02-000 |
| Boiler protection thermal snap-switch | B064-01-113 |

* *This adaptor flange is required to fit the P12R12A baffle and isolation valve to the 18B4B pump, and is only available for EHVI flanged pumps.*

Table 14 - 18B4B pump spares

| Spare | | | | Item Number |
|--------------------------------------|--------------|---------------------------------|---------------|-------------------|
| Apiezon AP201 pump fluid (4 l) | | | | H026-01-054 |
| Apiezon AP201 pump fluid (20 l) | | | | H026-01-052 |
| 18B4B spares kits | | | | |
| EHVI flanges | | | | B065-10-800 |
| ANSI flanges | | | | B065-20-800 |
| ISO flanges | | | | B065-30-800 |
| Heater spares packs * | | | | |
| | Pump voltage | Nominal voltage (connection) | Part number † | |
| | 200 - 210 V | 200 V (Delta) | H017-08-012 | H017-08-015 |
| | 220 - 230 V | 220 V (Delta) | H017-08-006 | H017-08-009 |
| | 240 - 250 V | 240 V (Delta) | H017-08-005 | H017-08-008 |
| | 380 - 400 V | 220 V (Star) | H017-08-006 | H017-08-009 |
| | 415 - 440 V | 240 V (Star) | H017-08-005 | H017-08-008 |
| | 460 - 480 V | 277 V (Star) | H017-08-014 | H017-08-017 |
| Seals | | | | Quantity supplied |
| 1 inch drain port 'O' ring | | | | 5 |
| Dipstick 'O' ring | | | | 2 |
| Main cone assembly 'O' ring | | | | 1 |
| Ejector cone 'O' ring | | | | 1 |
| Backing drain plug 'O' ring | | | | 5 |
| Cleaning port gasket | | | | 1 |
| Interior gasket | | | | 1 |
| Inlet 'O' ring (EHVI/ANSI) | | | | 1 |
| Inlet 'O' ring (ISO) | | | | 1 |
| 'T' piece/boiler 'O' ring | | | | 1 |
| Backing flange 'O' ring (EHVI/ANSI) | | | | 1 |
| 2 inch backing union 'O' ring (EHVI) | | | | 2 |

* Heater spares packs contain heaters, crimps, terminals, wires and ceramic insulation beads.

† As marked on the heater.

Index

A

Accessories 51
Adjust the boiler protection thermal snap-switch 33
Assemble and fit the new heater 46
B
Boiler-protection thermal snap-switch 3
C
Cautions 1
Check the heater clamp plate and retaining nuts 47
Check the insulation resistance of the heaters 31
Check the pump fluid-level 38
Clean and inspect the pump 39
Clean the boiler and fluid return pipes 41
Clean the cooling-coil 47
Clean the interior components 41
Clean the main pump components 40
Clean the radiation shield 43
Connect the boiler protection thermal snap-switch 25
Connect the cooling-fail thermal snap-switches 25
Connect the electrical supply 20
Connect the optional fluid low level switch 29
Connect the optional Pt100 temperature probe 25
Connect the pump inlet 18
Connect the pump outlet 18
Connect the supply to the pump 21
Connect the thermal snap-switches 25
Construction 2
Construction materials 9
Cooling-fail thermal snap-switches 3
Cooling-water connections 19
Cooling-water data 8
D
Description 1
Dismantle the pump 39
Disposal 49
E
Electrical data 9
Electrical safety 20

F

Fault finding 47
Fill the pump with fluid 26
Filling procedure 27
Filling procedure for adjustment of the fluid low level switch 29
Free-standing installation 17
G
General filling procedure 27
General requirements 16
I
Identify and remove the defective heater 44
Inspect the pump fluid 38
Installation 15
Installation on a vacuum system 16
Introduction 1, 27, 31, 51
L
Leak test the system 26
Locate the pump 16
Low fluid level protection 3
M
Maintenance 37
Maintenance plan 38
Mechanical data 8
O
Operating and storage conditions 7
Operation 31
Operation with high ambient humidity 3
Over-temperature protection 3
P
Performance 7
Prepare the pump 43
Prepare the pump for operation 42
Principle of operation 2
Pump fluid data 8
Pump fluid drain connection 20
Pump Item Numbers 10
R
Re-admission of air to your vacuum system 34
Reassemble the pump 41, 46
Recommended pump fluids 27
Re-evacuation of your vacuum system 34
Replace a pump heater 43
Rough pumping 32

Index

S

Safety 15, 37

Safety of vapour pump fluids 26

Scope and definitions 1

Service 51

Service, spares and accessories 51

Shut-down 34

Spares 51

Start-up 32

Storage and disposal 49

System design 17

T

Technical data 7

Temperature indication 3

Tools and equipment required 37

U

Unpack and inspect 15

V

Vacuum connections 17

W

Warnings 1