



Suction/Inter-Stage Fuel Gas Scrubber *Saturated Natural Gas*

EQUIPMENT

- Rotary Screw Compressors
- Reciprocating Engines/Gen-Sets
- Blowers for Gas Boosting
- Gas Turbines

APPLICATIONS

- Landfill and Bio-Gas Recovery
- Fuel Gas for Engines/Turbines
- Gas Compression
- Gas Pipeline Boosting

FEATURES

- Protects Equipment from Liquid and Particulate Entrained in the Gas Stream
- Multi-Stage Separation
 - 316 SS Vane Pack for Liquid Removal
 - 316 SS Mesh Pad for Trace Liquid Removal
 - Optional 99+% High Efficiency Filter Element
- Carbon Steel Construction
- Fabricated in Accordance with ASME Vessel Code Section VIII Division I
- Designed for Specific Application Conditions

OPTIONS

- Special Standards: PED, CRN, ATEX
- Stainless Steel Construction
- Special Coatings or Finishes
- Replaceable Filter Elements Available in Various Efficiencies for Particulate Filtration
- Gauge Ports, Float Switches
- Custom Leg Support Stand
- Flush Port for Vessel Cleaning
- Removable Vessel Top for Element Service
- Davit Arm for Vessel Top Removal

SAMPLE CONFIGURATION

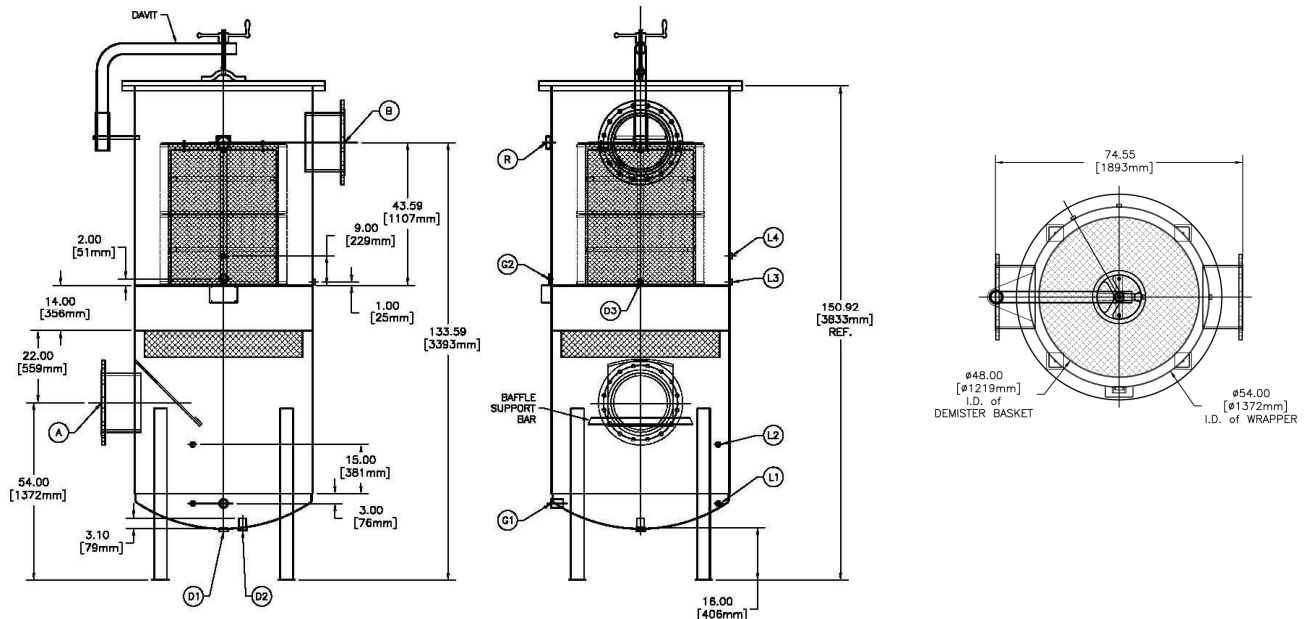

Discover the Possibilities
ISO 9001:2000 Certified

Solberg Manufacturing Inc
1151 Ardmore Ave. • Itasca, IL 60143 USA
Sales/Service: 630.773.1363 • Fax: 630.773.0727
E-mail: sales@solbergmfg.com • Web Site: www.solbergmfg.com

SSCRB-9334