

DATA SHEET

JET-3™ Centrifugal Blower by JETAIR™

The JET-3™ is ideal for air knife drying, vacuum, fluidized bed, cooling and exhaust applications. The JET-3™ is the most compact centrifugal blower available and features belt-free DirectDrive™ Technology.

JetAir Technologies' JET-3™ Blower is the most efficient blower in its class engineered for moderate flow and moderate pressure applications from 10HP[7.5kW] to 20HP[15kW]. The JET-3™'s Direct Drive design and compact footprint enable it to fit into the widest range of OEM equipment.

JetAir's **Direct Drive** Technology (US & Int'l. Pat. Pend.) is enabled by a proprietary high-speed motor and an aerodynamically designed blower.

DirectDrive Side View

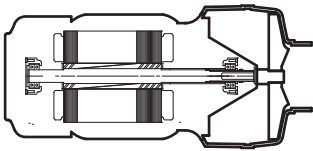

DirectDrive™ enhances reliability and boosts performance by eliminating belts, tensioning devices and complex spindle assemblies common in other high-speed blowers.

The JET-3™'s aerodynamic belt-free design and advanced impeller achieve industry leading efficiency. A JET-3™ is 10-12% more efficient than our belt-drive competitors and in many cases, a JetAir blower outperforms multiple competitors' blowers using significantly less energy!

JetAir's Direct Drive Technology and efficiency also accelerate payback and energy savings when converting compressed air systems to JET-3™ Blowers.



The compact size of the JET-3™ simplifies air knife installations, OEM integration and enclosure requirements, lowering costs and handling time.

Contact JetAir for size air knife application sizing, systems integration and more information.

All JetAir Engineered Solutions are 100% Guaranteed.



USA & International
Patents Pending

ADVANTAGES. WHY A JET-3?

EFFICIENT POWER. JET-3™ is 10-12% more efficient than belt drive units. Available in 10-20HP or [7.5-15kW] ratings.

- Flow: 1200cfm [2040M³Hr]
- Pressure: 110"WG [275mBar]
- Vacuum: 96"WG [240mBar]

MOST COMPACT. Smallest Footprint. One Man Install. Fed-X, DHL, and UPS Delivery Available. (See dimensions on reverse side.)

MORE RELIABLE. Built-in Motor Protection. Ultra-Balanced Motor Shaft. 1 Yr. Warranty, Fewer Parts.

BETTER ROI. Most Efficient Power Use. No Belts or Adjustment Costs. Lowest Delivery Costs.

SMART CONTROL. Variable Frequency Drive (VFD) Control enables precise airflow settings, higher efficiencies, PLC connectivity, motor protection and non-spiking soft-starts.

JETAIR™

TECHNOLOGIES, LLC

1756 Eastman Ave., #100, Ventura CA 93003
805-654-7000 main, 805-654-7064 facsimile
www.jetairtech.com or sales@jetairtech.com

Technical Specifications

JET-3™ High-Speed Centrifugal Blower

DESCRIPTION: DirectDrive™ Technology, Single Stage Centrifugal Compressor, Oil-Less, Spindle Free Design.

DRIVE SYSTEM: DirectDrive™ Technology, with Variable Frequency Drive Control. Integrated Motor Protection, Air Cooled Rated: 105°F [40°C]

IMPELLER: 5 Axis C355 Aluminium

AERO-BLOWER: A356-T6 Aluminum with Integrated Lifting Eye.

HIGH-SPEED MOTOR: TEFC, IP54, External Junction Box, 10-20HP [7.5-15kW] 3-Phase, 190-220, 390-480 and 600VAC, 50/60Hz, Thermister, 105°F [40°C] Ambient.

WEIGHT: 79lbs. [36kg]

CONNECTIONS: Inlet 5"Ø [126mm], Outlet 4"Ø [102mm], 360° Rotation.

WARRANTY: 1 Year.

Performance Curve: JET-3™

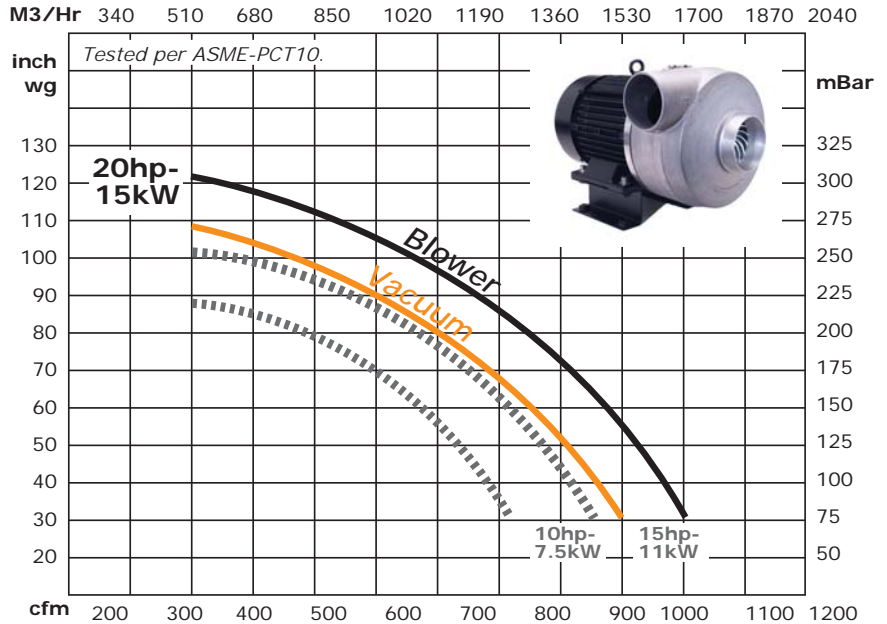

FILTER ELEMENTS:
 Polyester Cylinder P/N FILT-J3-POLY
 Polyester for Enclosure P/N FILT-ENC-POLY



ENCLOSURE: Blower & Variable Frequency Drive
 Stainless Steel NEMA4X [IP66] Washdown
 Enclosures; 36x22x20" [914x56x51]; includes
 Filter Assembly & Gage and Disconnect

Enc36 P/N ENC36-S4-AUX
 Enc36 - HIM/Stop/Sel P/N ENC36-S4-HSS
 Enc36 Leg/Levelers P/N ENC36-LEGS

Model JET-3™

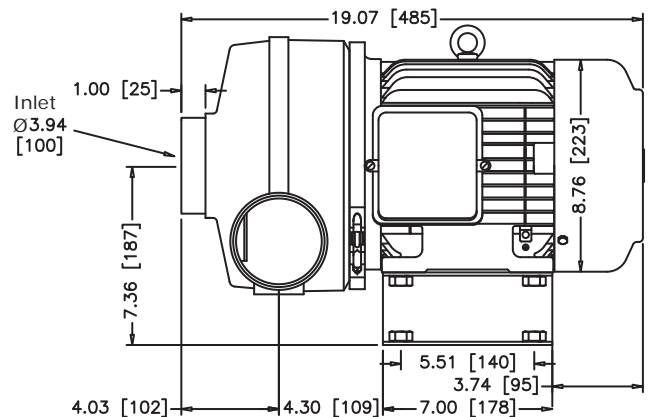
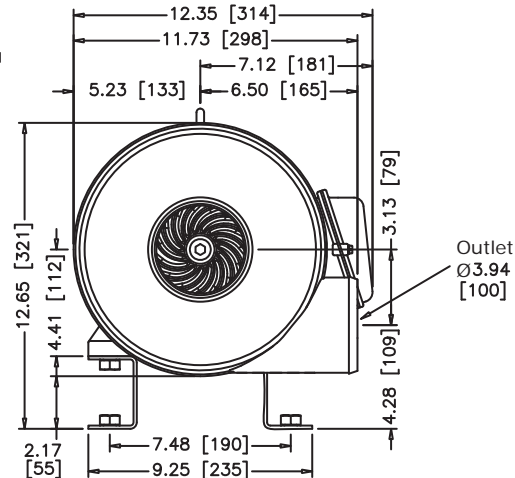

JETAIR™

TECHNOLOGIES, LLC

1756 Eastman Ave., #100, Ventura CA 93003
 805-654-7000 main, 805-654-7064 facsimile
 www.jetairtech.com or sales@jetairtech.com

